

## PHYS 4211 Instrumentation HW 3

TE Coan  
Fall '09

1. Problem 4.1, Horowitz and Hill, p. 181. Not that it matters for this problem, but for a *pnp* transistor,  $V_E - V_B \simeq 0.6\text{ V}$ , the opposite for the *npn* transistor you are more familiar with.
  
2. Write down the two simultaneous equations in  $x$  and  $y$  that the analog computer circuit in the figure is set up to solve. ( $R = 1\text{ M}\Omega$ .) Voltages at the pots are indicated, with the letter indicated the fraction of the maximum possible voltage. This circuit is less complicated than it might seem at first blush. You built a subset of it in lab!

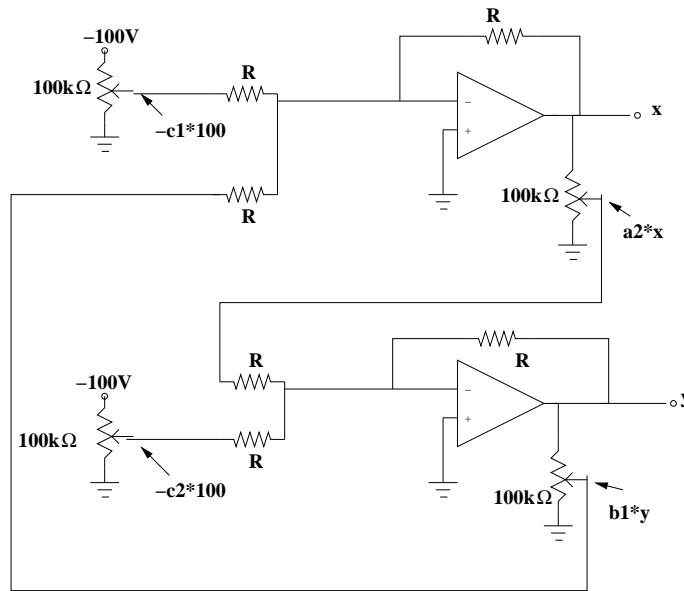

Figure 1: Analog computer circuit that solves for  $x$  and  $y$ .

3. Using our op-amp golden rules, explicitly derive the result for  $V_{out}$  shown in Figure 4.18 in Horowitz and Hill, p185.