

Spacetime Diagram

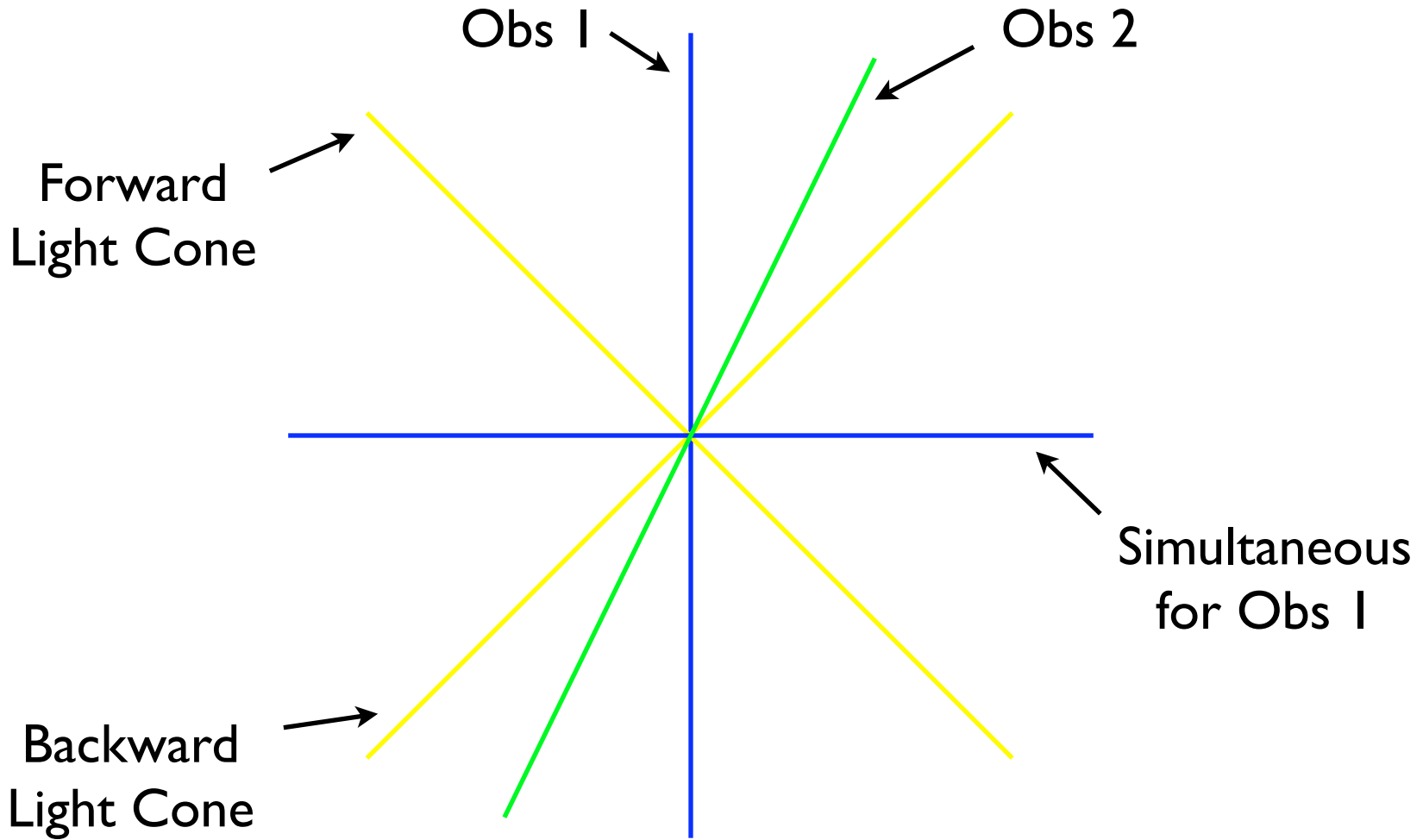

Observer 1 :

Observer 2 :

Inertial Observers :

Do not accelerate. Follow straight lines in spacetime diagrams.

Are equivalent to each other -
Relativity Principle.

All see light moving at
precisely same speed :

$$c = 299,792,458 \text{ m/s}$$

Events :

Events are single points in spacetime. They are occurrences that take place over an extremely short time within an extremely small region.

Worldlines:

Worldlines are the curves mapped out by observers. The worldlines of inertial observers are straight lines.

Proper Time :

Proper time between two events is the time measured by an observer which passes through those events.

Time Dilation :

The proper time measured between two events on the worldline of an inertial observer is shorter than the time measured between those events by any other inertial observer. Time is dilated (stretched) for observers which do not pass through both events.

Time Dilation

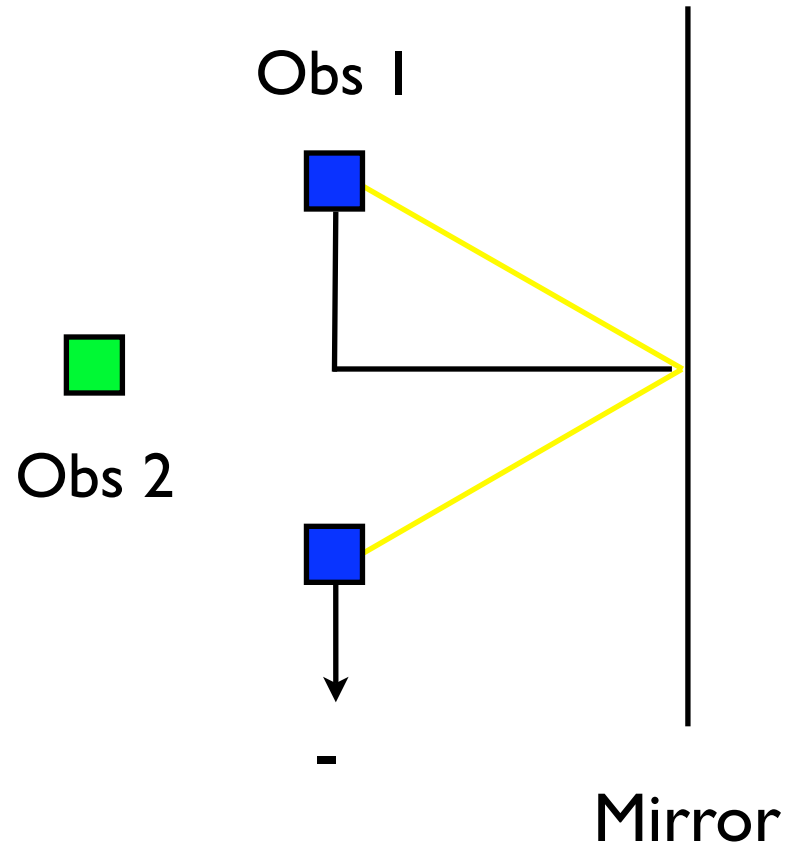
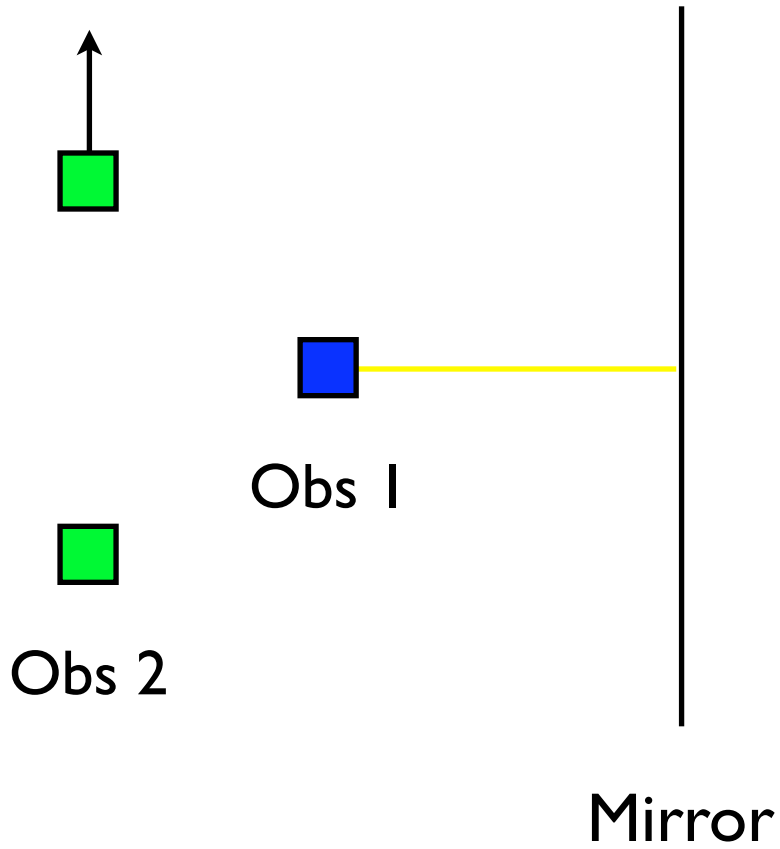

Time Dilation

Since :

And :

Time measured between two events by inertial observers is shortest for observer which passes through both events. Proper time is shortest.

Events chosen to have
same proper time.

Event • :

Event • :

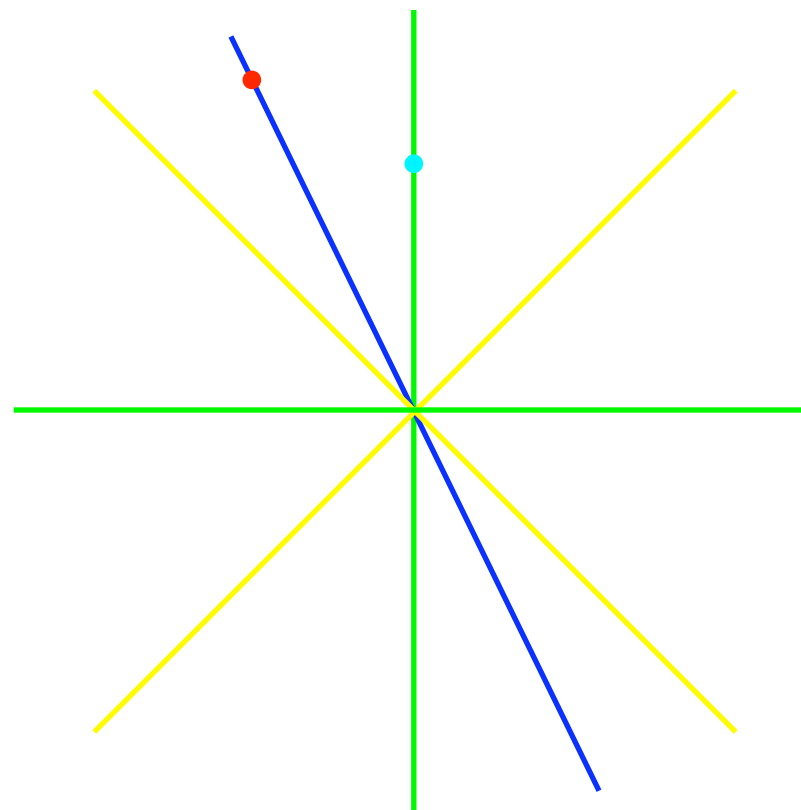
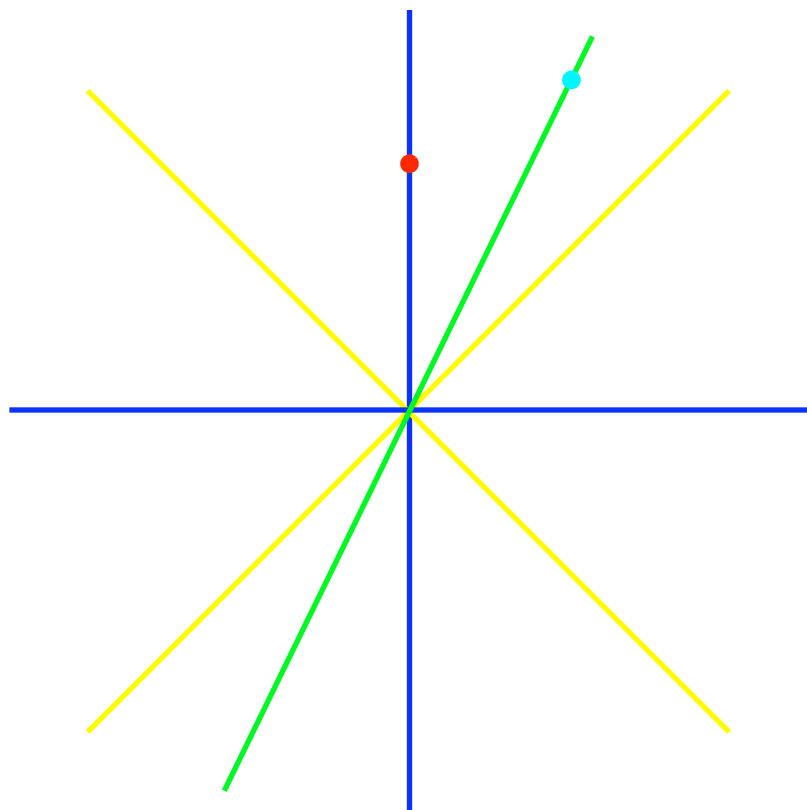

Failure of Simultaneity

Events that are simultaneous to one inertial observer are not simultaneous to another.

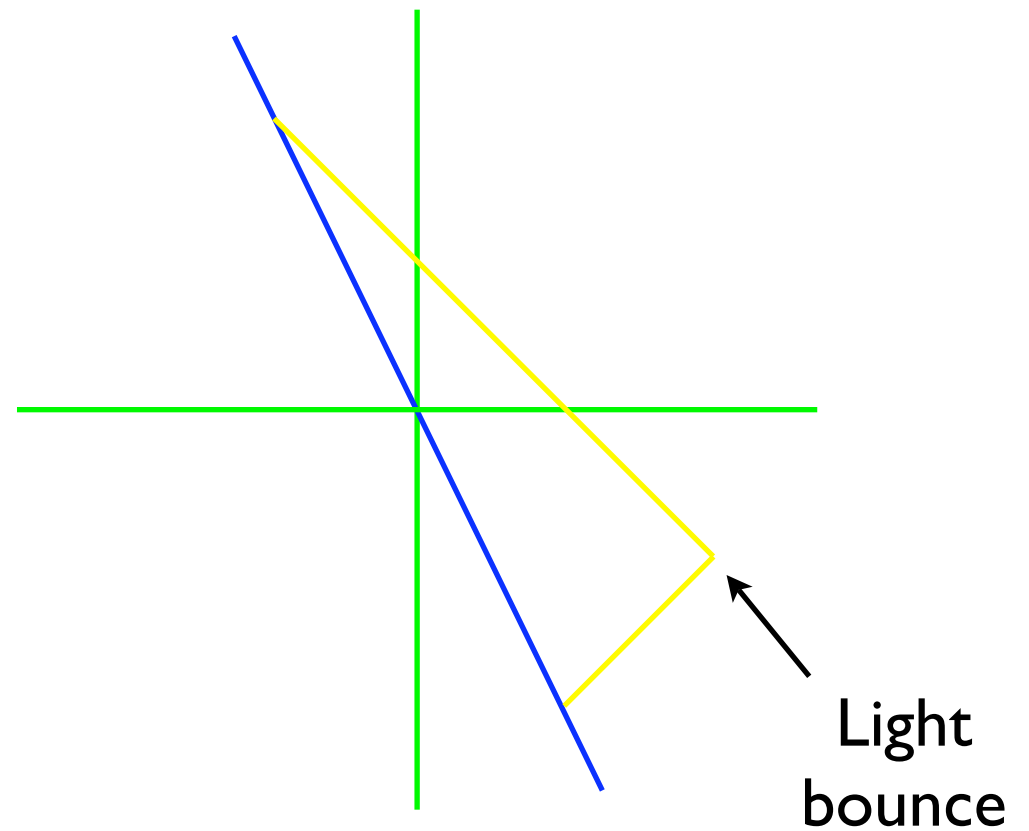
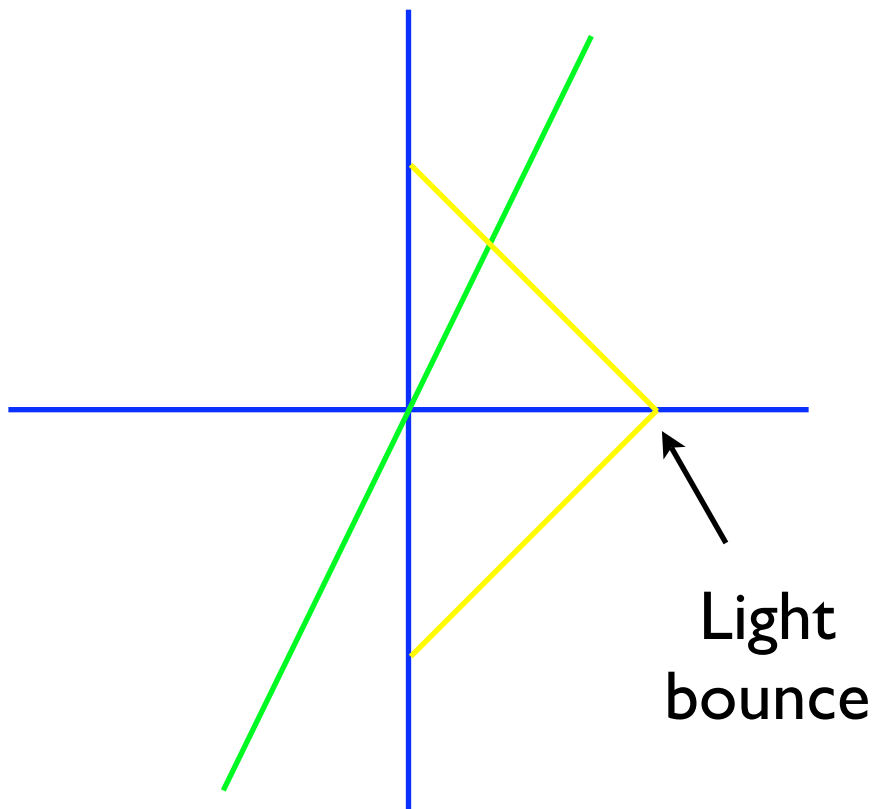

This allows us to draw both axes on both diagrams.

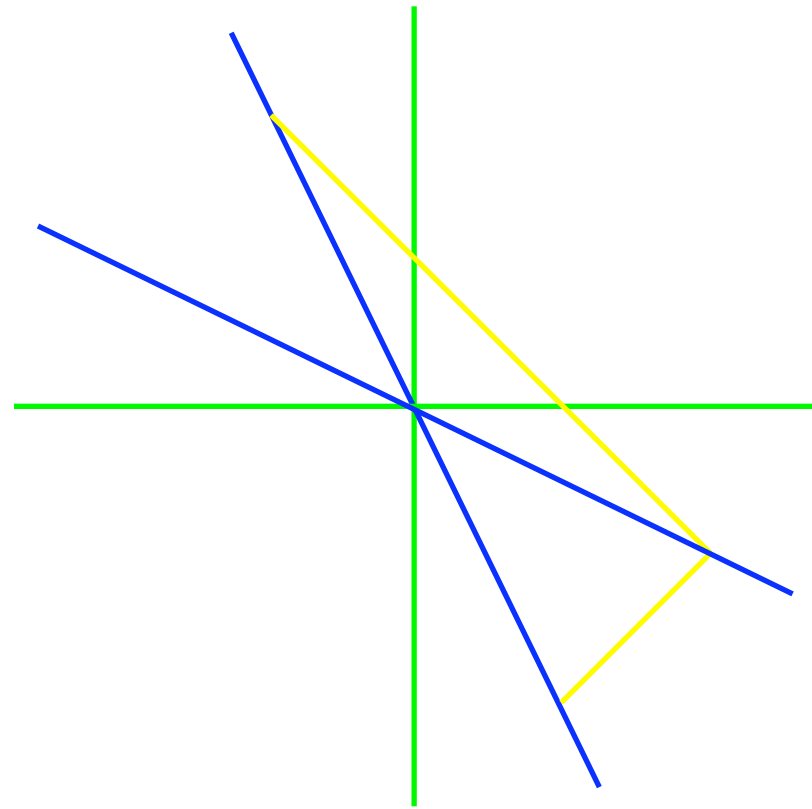
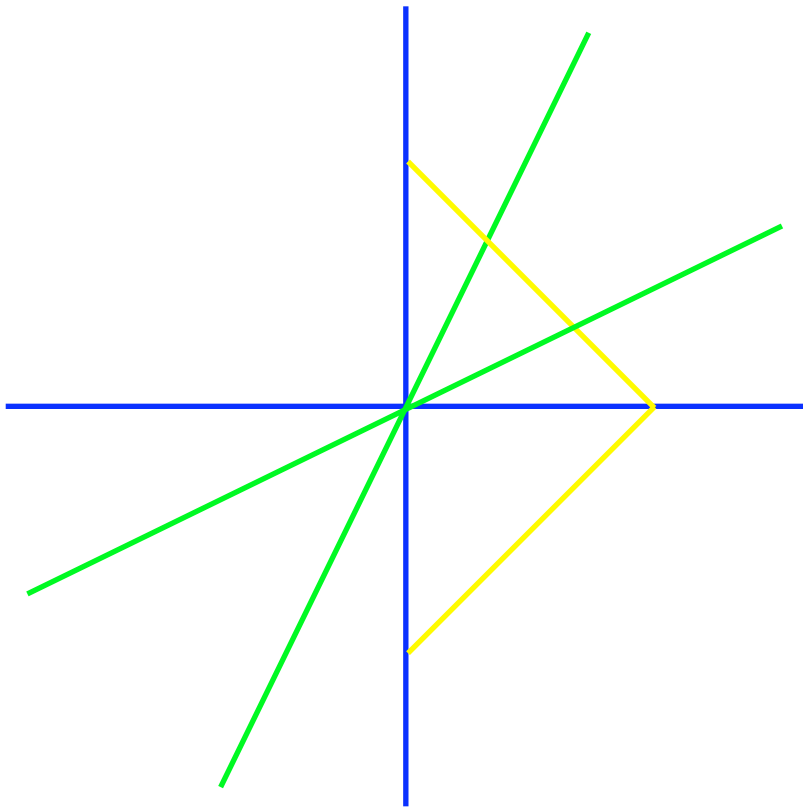

Since angles are equal we can get equation for $t=0$ line from $x=0$ line.

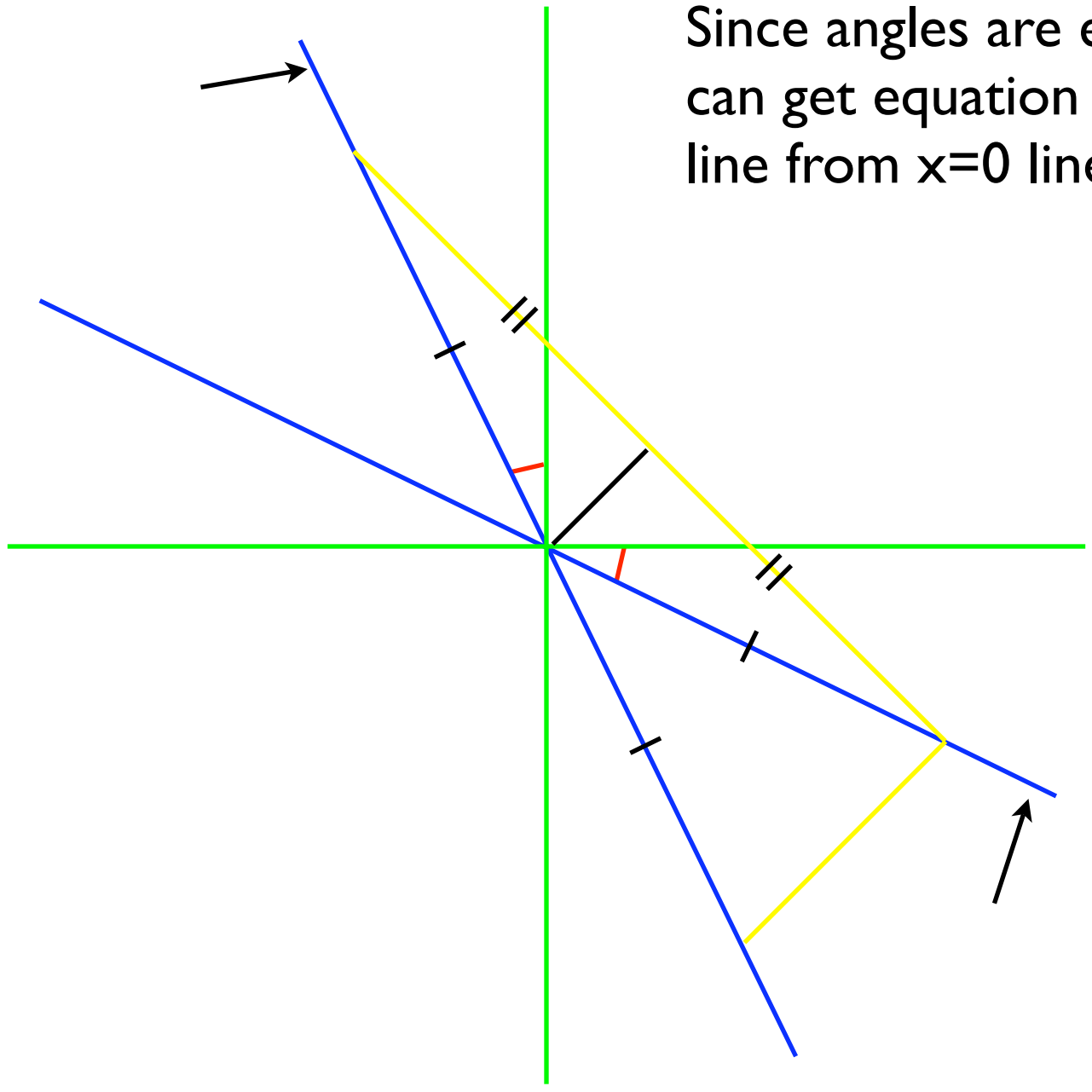

Length Contraction

Obs I at Rest

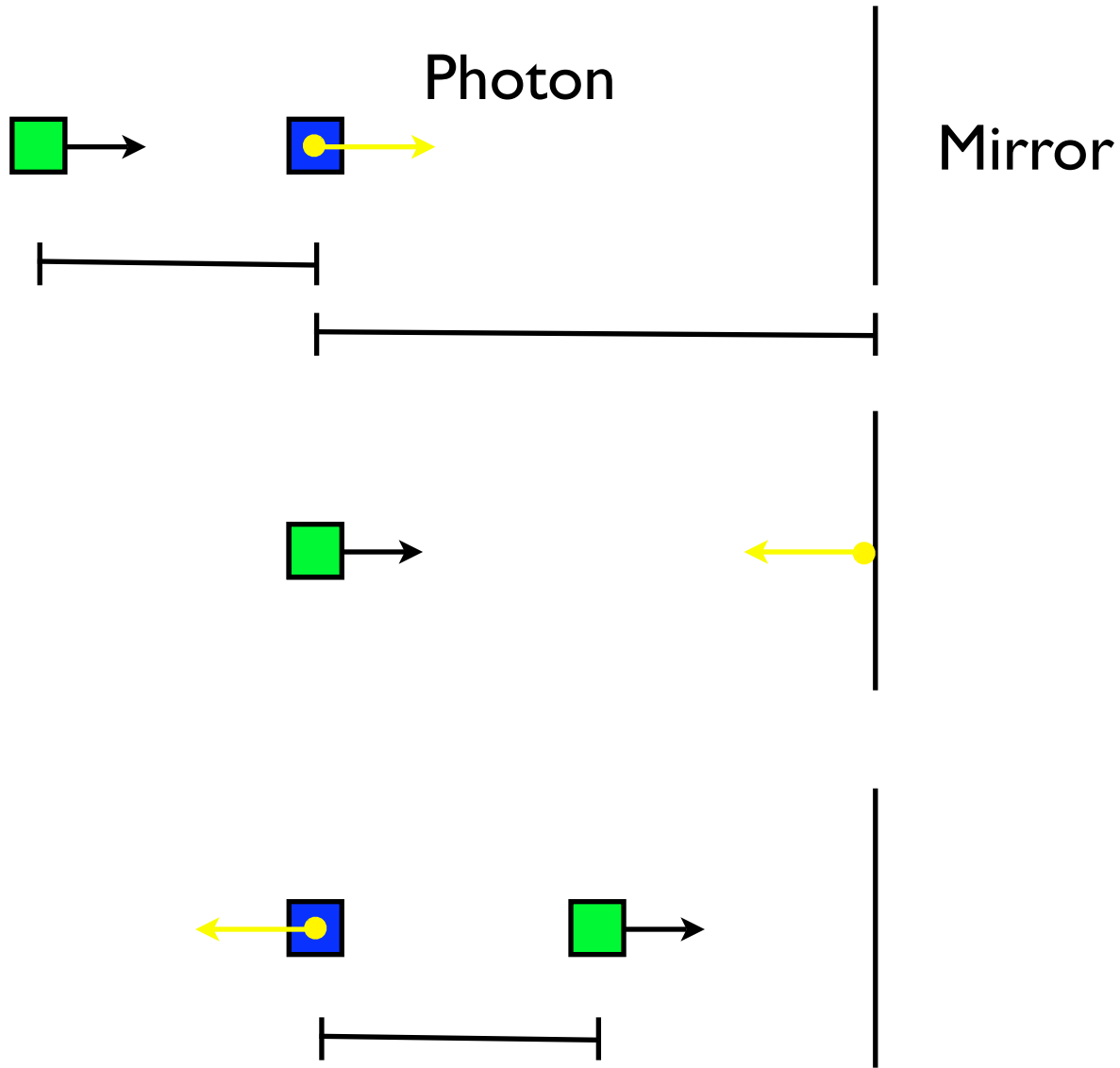

Length Contraction

Obs 2 at Rest

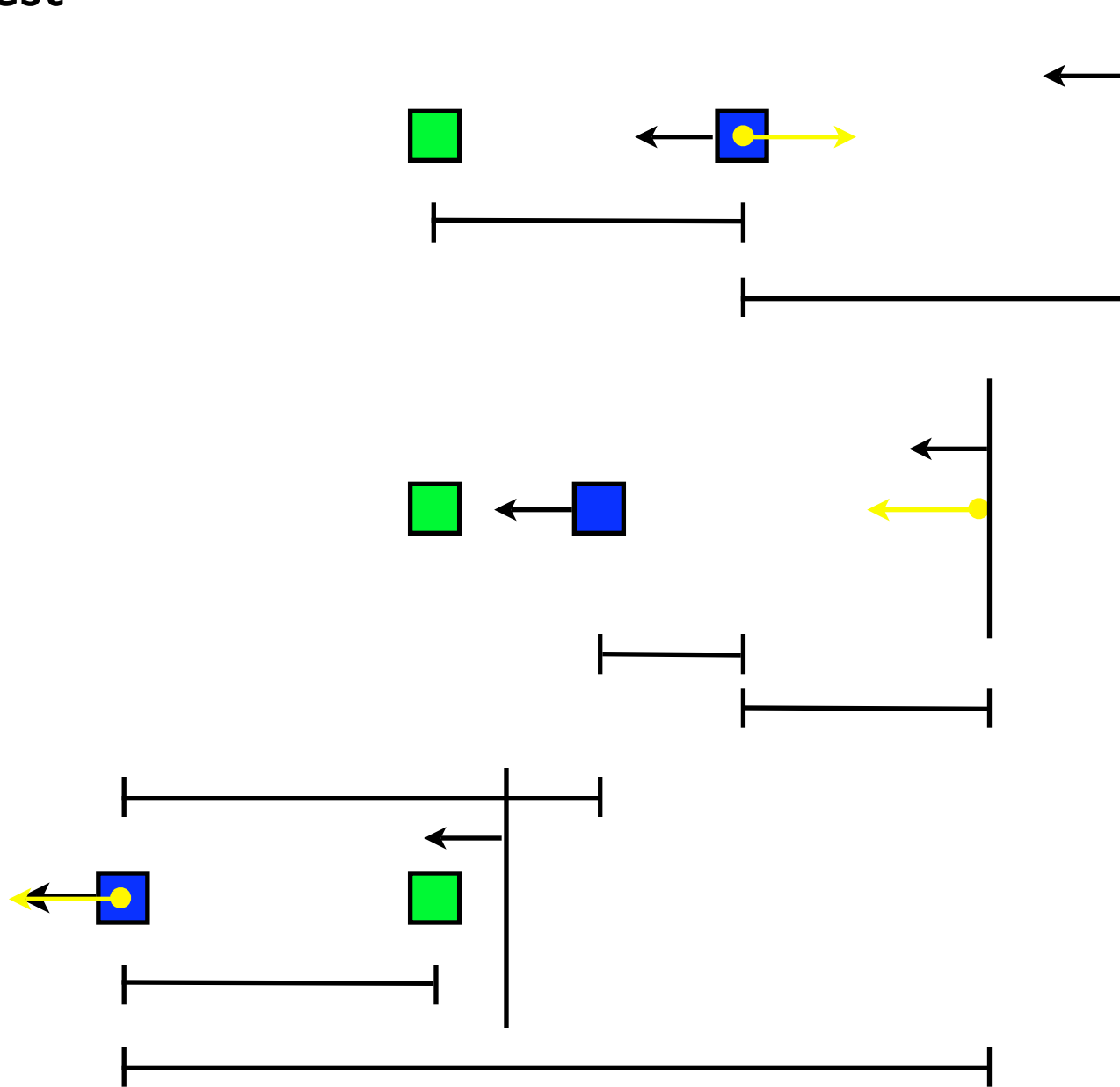

Length Contraction

Since :

And :

The length of an object is longest for an inertial observer which is at rest with respect to the object. Proper length is longest.

Length Contraction

Obs 1 at Rest

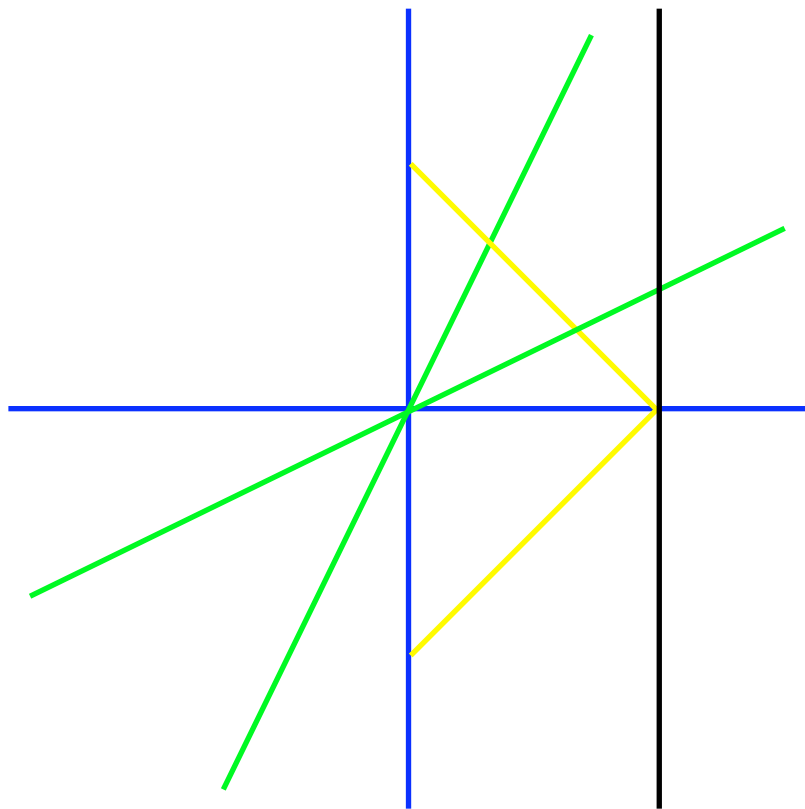

Obs 2 at Rest

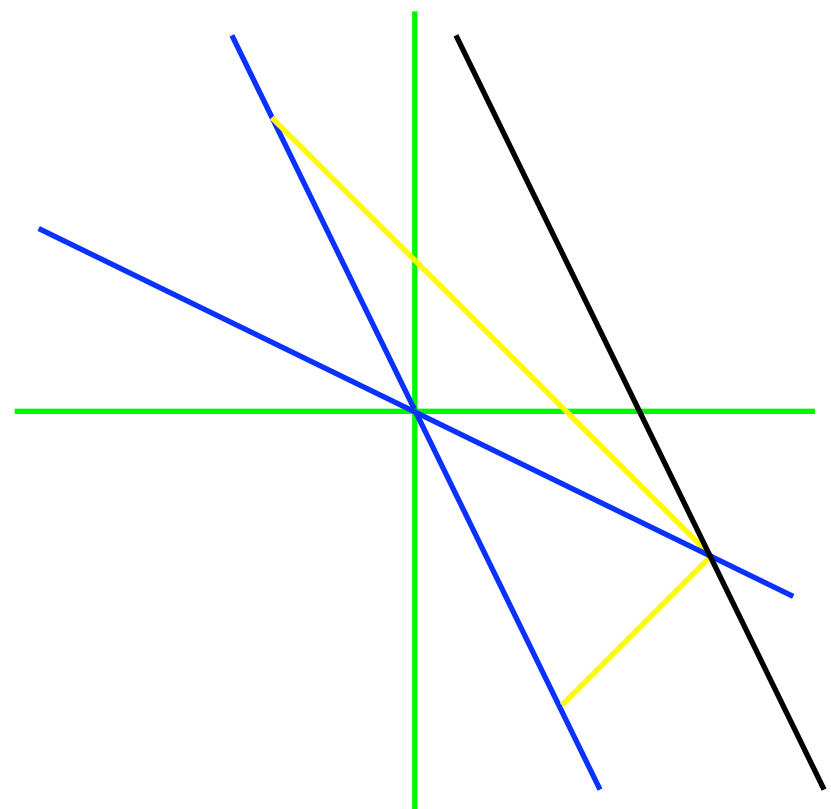

Length Contraction

Obs I at Rest

Mirror

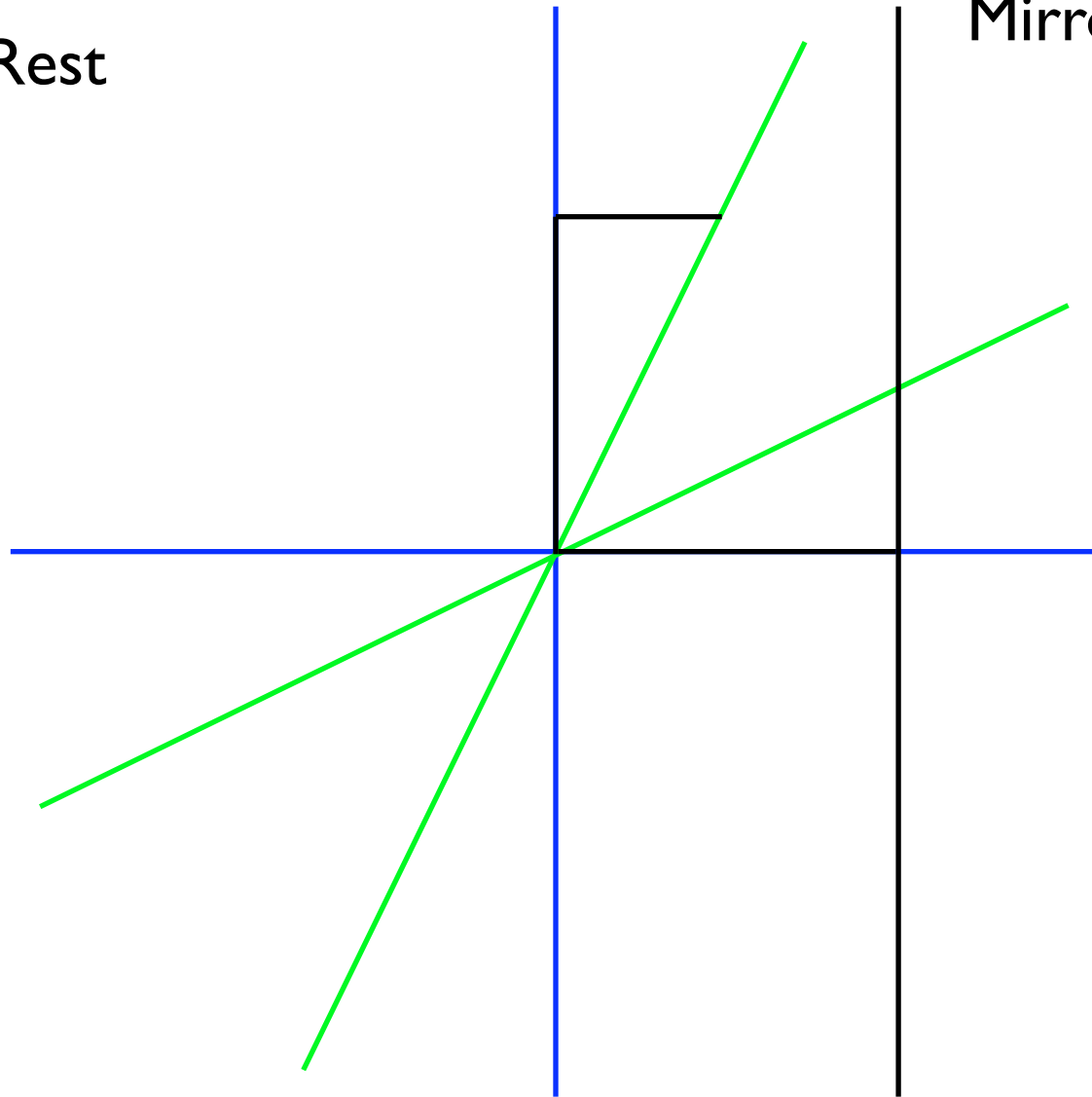

Length Contraction

Obs 2 at Rest

Mirror

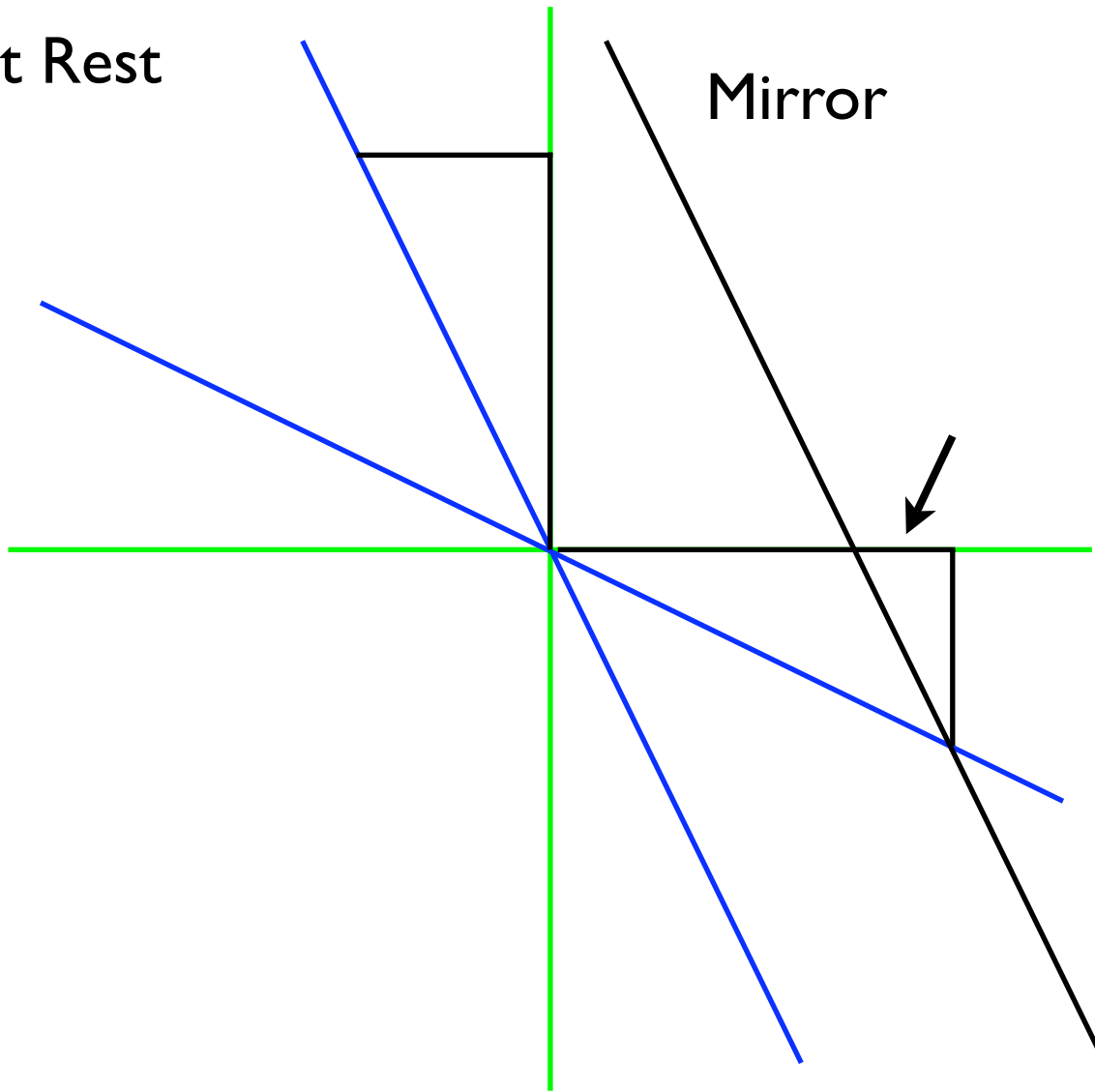

Twin 1
at rest

Twin "Paradox"

Earth

Venus



Time between
planets proper
time for twin 2

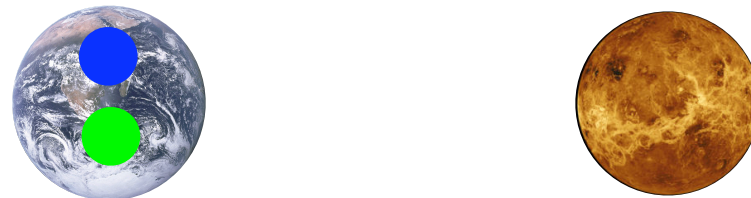

Twin 1
ages
more

Twin “Paradox”

Note that twin 2 sees planets as closer :

But twin 2 sees planets moving at same speed as they see him moving :

All inertial observers are equivalent. The ultimate reason for the difference in aging is that twin 2 is not an inertial observer, he accelerates when he turns around.

Twin "Paradox"

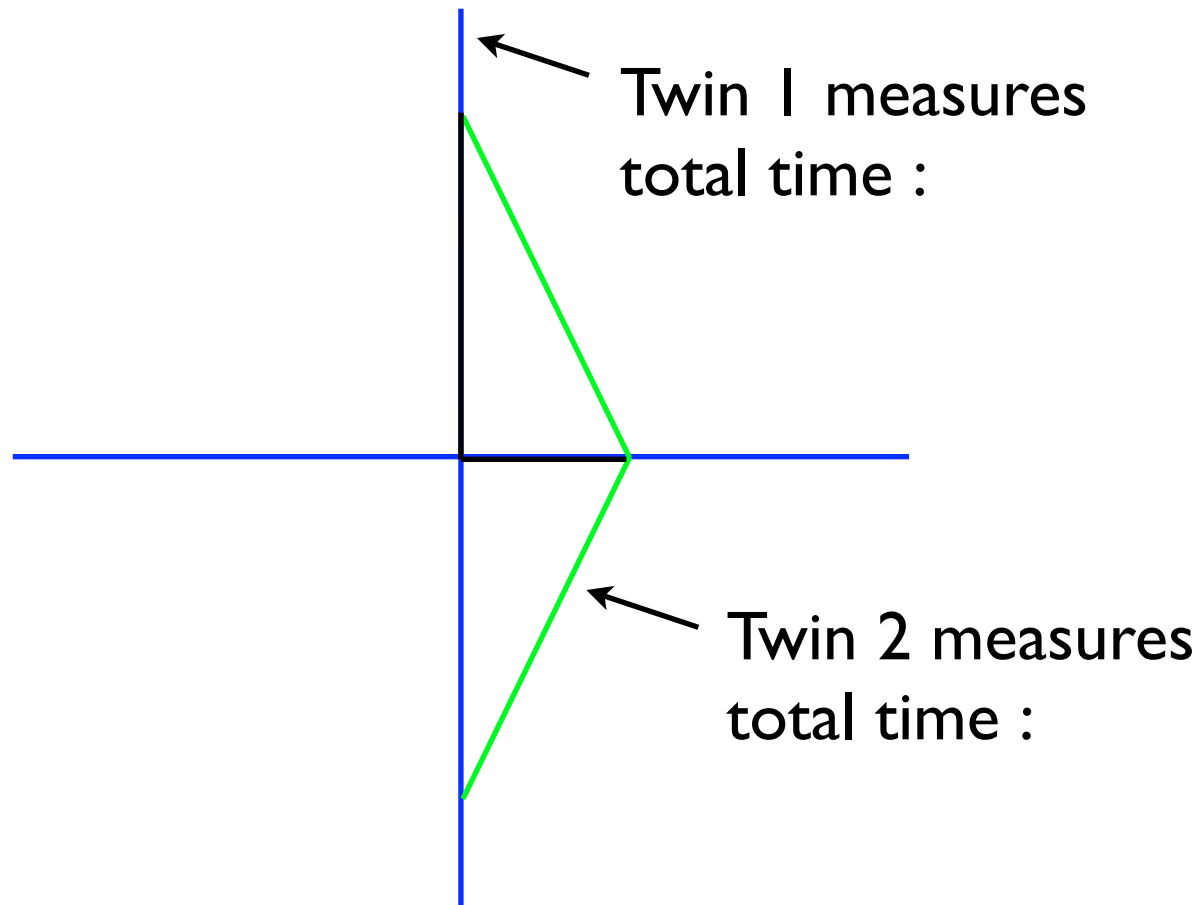

There is no spacetime diagram like this for twin 2 at rest since he is not inertial. He does not follow a straight line in spacetime.