

Primary and secondary vertex

- Primary and Secondary Decay Vertices

- Example: B lifetime $\tau_B \sim 1.6 \text{ ps} \Rightarrow \gamma c \tau_B = \gamma \cdot 500 \text{ } \mu\text{m}$ with $\gamma = \frac{1}{\sqrt{1 - \frac{v^2}{c^2}}}$
- Figure of merit: **Impact parameter resolution**

- Physics example from LHCb (2010): $B^+ \rightarrow J/\Psi K^+$

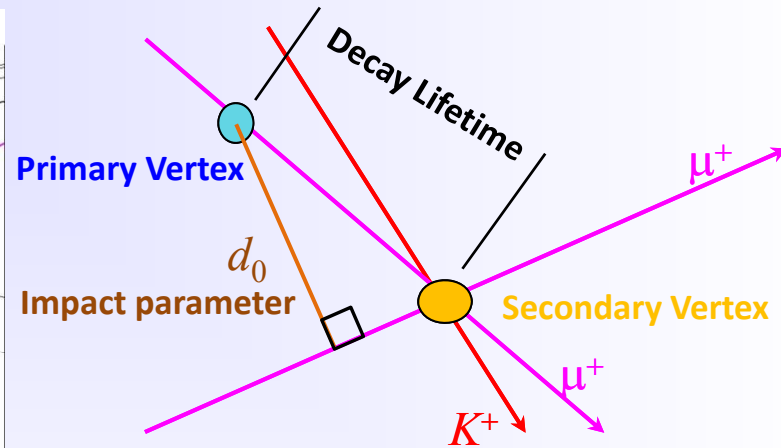
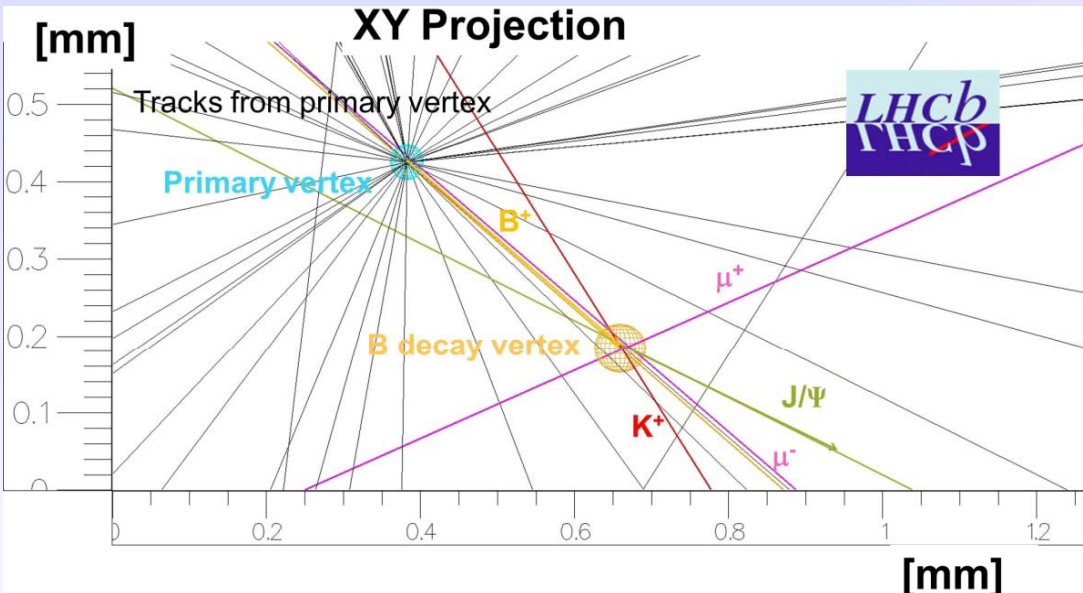

- Uncertainty on the transverse impact parameter, d_0 , depends on the detector radii and space point precisions.
- Simplified formula for just two layers:

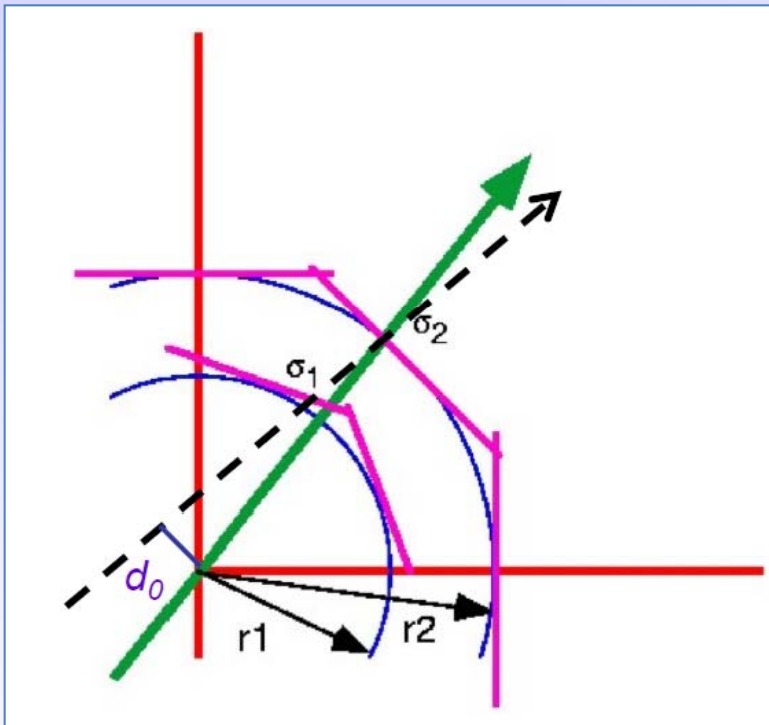

$$\sigma_{d_0}^2 = \frac{r_2^2 \sigma_1^2 + r_1^2 \sigma_2^2}{(r_2 - r_1)^2} + \sigma_{MS}^2$$

– Suggests small r_1 , large r_2 ,
small σ_1, σ_2

– But precision is degraded
by multiple scattering .

Example: **LHCb (VELO)**

$$\sigma(\text{IP}) = (10 + 29/p_T [\text{GeV}/c]) \mu\text{m} \quad [\text{PoS VERTEX2010:014,2010.}]$$

from Michael Moll

**In the following are included slides from excellent set of lectures by
Francesco Ragusa at the 2006 Italo-Hellenic School of Physics
in Martignano, Italy**

Tracking

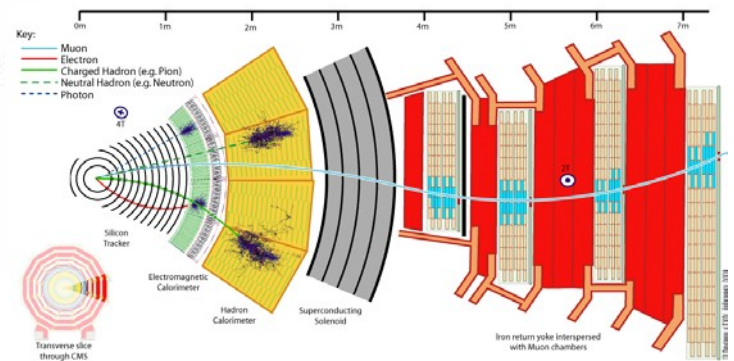
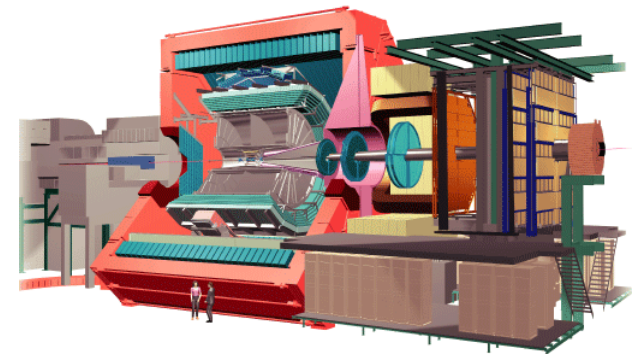
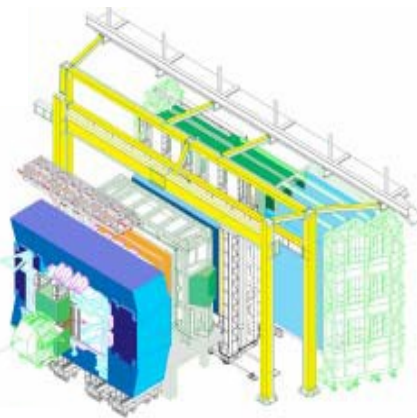
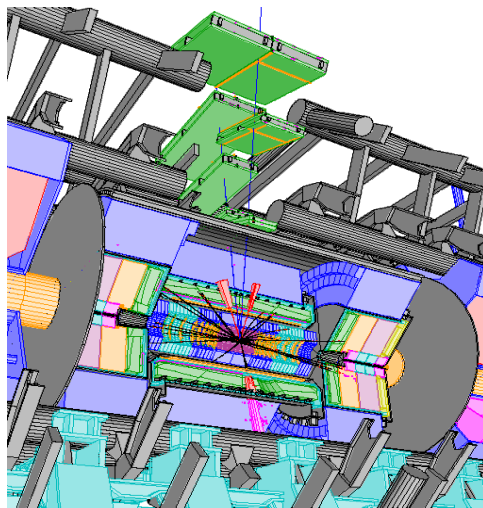

Based on lectures by F. Ragusa at the Italo-Hellenic School of Physics

Contents

LECTURE 1

Introduction

Motion in magnetic field

Helical trajectories

Magnetic spectrometers

Tracking Systems: ATLAS & CMS

Straight line fit

Error on the slope

Error on the impact parameter

Vertex detector and central detector

Momentum measurement

Sagitta

Tracking in magnetic field

Quadratic (parabola) fit

Momentum resolution

Extrapolation to vertex

LECTURE 2

Transport of parameters

Multiple Scattering

covariance matrix

momentum resolutions at low momenta

impact parameter resolution at low momenta

Measurement of the sign of charge

Systematic effects

misalignments and distortions

Kalman Filter

Introduction

Tracking is concerned with the reconstruction of charged particles trajectory (tracks) in experimental particle physics

the aim is to measure (not a full list)

momentum (magnetic field)

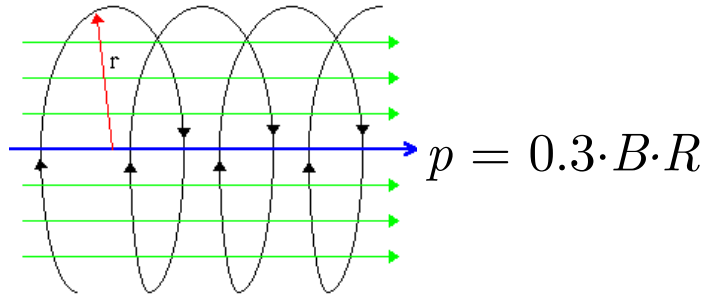

lifetime tag

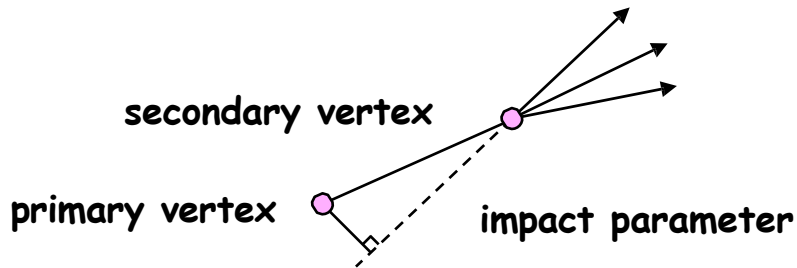

the sign of the charge

$$\mathbf{F} = q \mathbf{v} \times \mathbf{B}$$

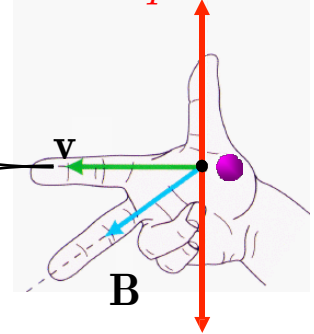

particle ID (mass), not necessarily with the same detector

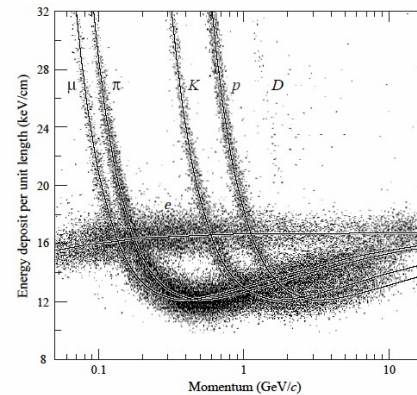

$$p = m_0 \gamma \beta$$

Motion in Magnetic Field

In a magnetic field the motion of a charged particle is determined by the Lorentz Force

$$\frac{d\mathbf{p}}{dt} = e \mathbf{v} \times \mathbf{B}$$

Since magnetic forces do not change the energy of the particle

$$m_0 \gamma \frac{d\mathbf{v}}{dt} = e \mathbf{v} \times \mathbf{B}$$

$$m_0 \gamma \frac{d^2 \mathbf{r}}{dt^2} = e \frac{d\mathbf{r}}{dt} \times \mathbf{B}$$

using the path length s along the track instead of the time t

$$ds = v dt$$

we have

$$m_0 \gamma v \frac{d^2 \mathbf{r}}{ds^2} = e \frac{d\mathbf{r}}{ds} \times \mathbf{B}$$

and finally

$$\frac{d^2 \mathbf{r}}{ds^2} = \frac{e}{p} \frac{d\mathbf{r}}{ds} \times \mathbf{B}$$

In case of inhomogeneous magnetic field, $\mathbf{B}(s)$ varies along the track and to find the trajectory $\mathbf{r}(s)$ one has to solve a differential equation

In case of homogeneous magnetic field the trajectory is given by a helix

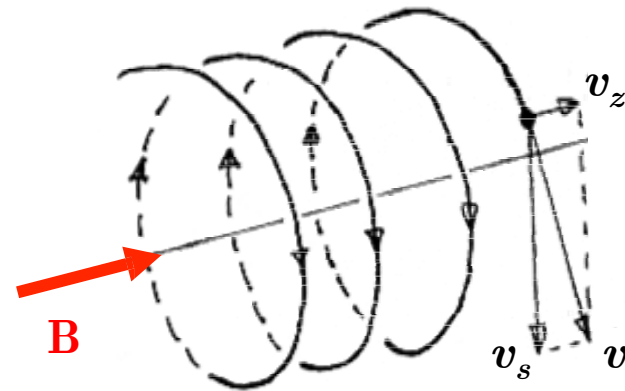

Magnetic Spectrometers

Almost all High Energy experiments done at accelerators have a magnetic spectrometer to measure the momentum of charged particles

2 main configurations:

solenoidal magnetic field

dipole field

Solenoidal field

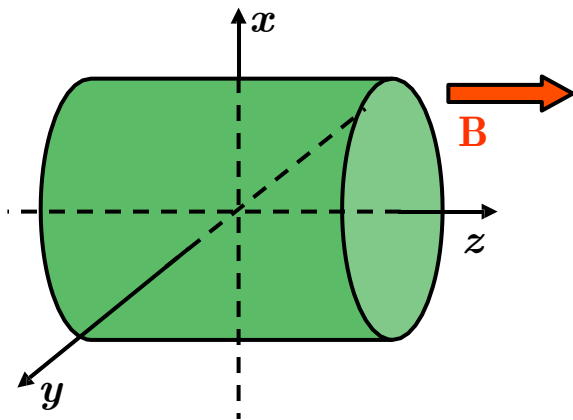

cylindrical symmetry

deflection in $x - y$ ($\rho - \phi$) plane

tracking detectors arranged in cylindrical shells

measurement of curved trajectories in $\rho - \phi$ planes at fixed ρ

Dipole field

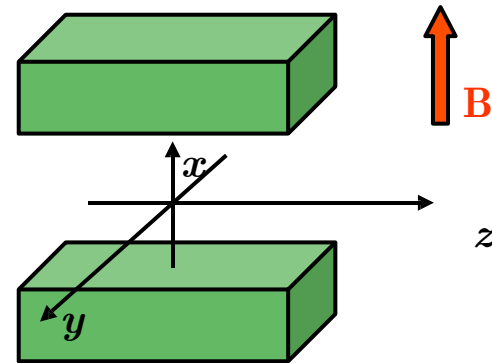

rectangular symmetry

deflection in $y - z$ plane

tracking detectors arranged in parallel planes

measurement of curved trajectories in $y - z$ planes at fixed z

Tracking Systems: ATLAS

Pixel Detector

3 barrels, 3+3 disks: 80×10^6 pixels

barrel radii: 4.7, 10.5, 13.5 cm

pixel size $50 \times 400 \mu\text{m}$

$\sigma_{r\phi} = 6-10 \mu\text{m}$ $\sigma_z = 66 \mu\text{m}$

SCT

4 barrels, disks: 6.3×10^6 strips

barrel radii: 30, 37, 44, 51 cm

strip pitch 80 μm

stereo angle $\sim 40 \text{ mrad}$

$\sigma_{r\phi} = 16 \mu\text{m}$ $\sigma_z = 580 \mu\text{m}$

TRT

barrel: $55 \text{ cm} < R < 105 \text{ cm}$

36 layers of straw tubes

$\sigma_{r\phi} = 170 \mu\text{m}$

400.000 channels

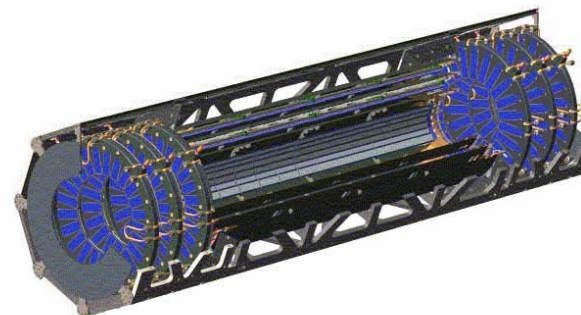
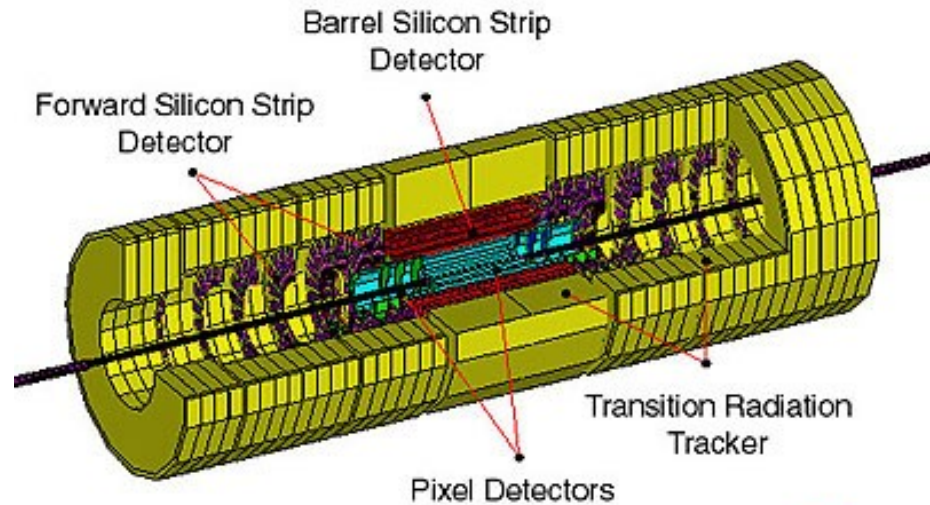

+ IBL

Tracking Systems: ATLAS & CMS



ATLAS

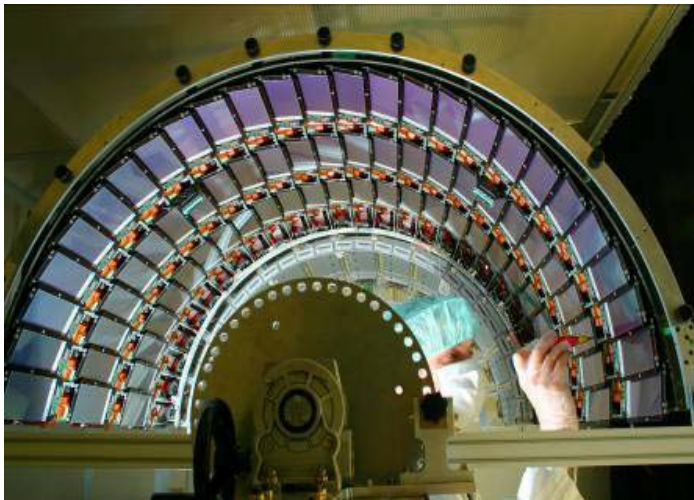
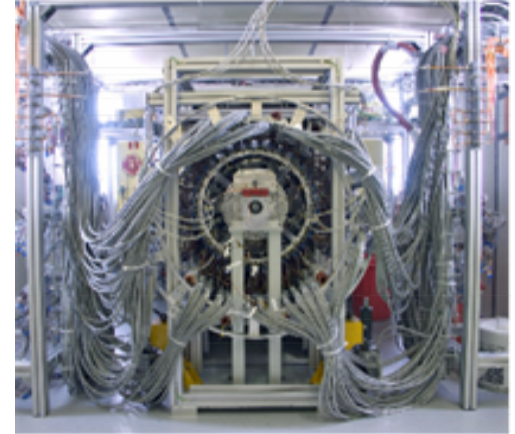

CMS



Momentum Measurement

The momentum of the particle is projected along two directions

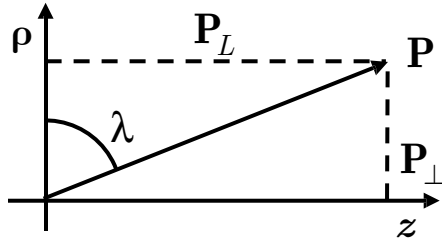

in $\rho - \phi$ plane we measure the transverse momentum P_{\perp}

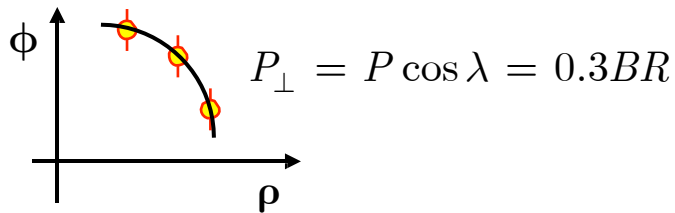

in the $\rho - z$ plane we measure the dip angle λ

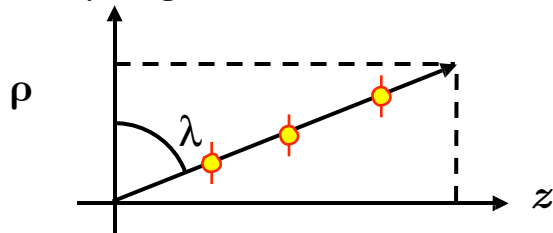

orders of magnitude

$$P_{\perp} = 1 \text{ GeV} \quad B = 2 \text{ T} \quad R = 1.67 \text{ m}$$

$$P_{\perp} = 10 \text{ GeV} \quad B = 2 \text{ T} \quad R = 16.7 \text{ m}$$

the sagitta s

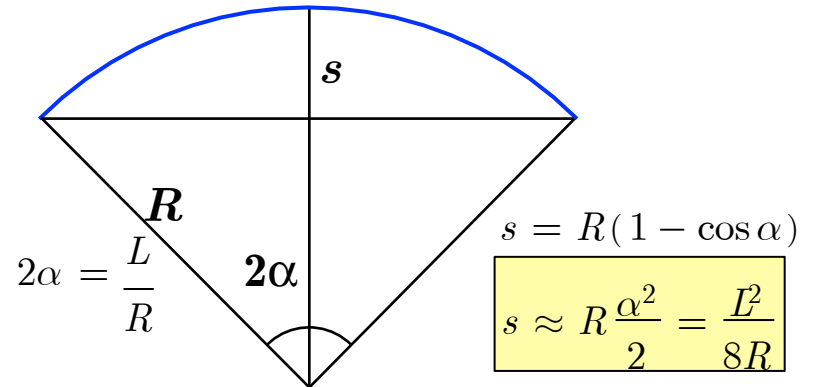

assume a track length of 1 m

$$P_{\perp} = 1 \text{ GeV} \quad s = 7.4 \text{ cm}$$

$$P_{\perp} = 10 \text{ GeV} \quad s = 0.74 \text{ cm}$$

Momentum Measurement

Once we have measured the transverse momentum and the dip angle the total momentum is

$$P = \frac{P_{\perp}}{\cos \lambda} = \frac{0.3BR}{\cos \lambda}$$

the error on the momentum is easily calculated

$$\frac{\partial P}{\partial R} = \frac{P_{\perp}}{R}$$

$$\frac{\partial P}{\partial \lambda} = -P \tan \lambda$$

$$\left(\frac{\Delta p}{p}\right)^2 = \left(\frac{\Delta R}{R}\right)^2 + (\tan \lambda \Delta \lambda)^2$$

We need to study

the error on the radius measured in the bending plane $\rho - \phi$

the error on the dip angle in the $\rho - z$ plane

We need to study also

contribution of multiple scattering to momentum resolution

Comment:

in an hadronic collider the main emphasis is on transverse momentum elementary processes among partons that are not at rest in the laboratory frame

use of momentum conservation only in the transverse plane

The Helix Equation

The helix is described in parametric form

$$x(s) = x_o + R \left[\cos \left(\Phi_o + \frac{hs \cos \lambda}{R} \right) - \cos \Phi_o \right]$$

$$y(s) = y_o + R \left[\sin \left(\Phi_o + \frac{hs \cos \lambda}{R} \right) - \sin \Phi_o \right]$$

$$z(s) = z_o + s \sin \lambda$$

λ is the dip angle

$h = \pm 1$ is the sense of rotation on the helix

The projection on the x - y plane is a circle

$$(x - x_o + R \cos \Phi_o)^2 + (y - y_o + R \sin \Phi_o)^2 = R^2$$

x_o and y_o the coordinates at $s = 0$

Φ_o is also related to the slope of the tangent to the circle at $s = 0$

$$R(m) = \frac{p_{\perp} (GeV)}{0.3B(T)}$$

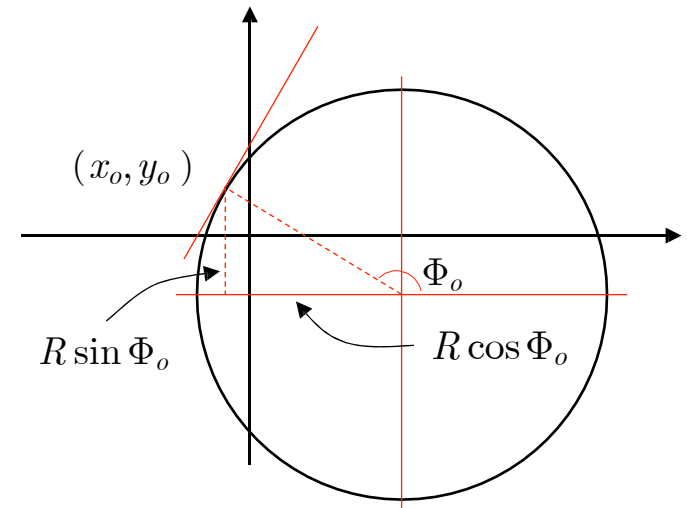
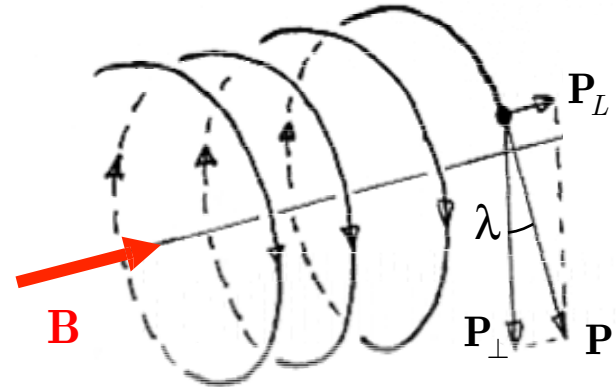

right-handed system

The Helix Equation

To reconstruct the trajectory we put position measuring planes along the particle path

We will consider the track fit separately in the the 2 planes

perpendicular to $B(x,y)$: circle

containing $B(x,z), (y,z)$ or (ρ,z) straight line

In the plane containing B (for example $y - z$ plane) the trajectory is a periodic function of z

$$y(s) = y_0 + R \left[\sin \left(\Phi_0 + \frac{hs \cos \lambda}{R} \right) - \sin \Phi_0 \right] \quad s = \frac{z - z_0}{\sin \lambda}$$

$$y(z) = y_0 + R \left[\sin \left(\Phi_0 + \frac{h(z - z_0)}{R \tan \lambda} \right) - \sin \Phi_0 \right]$$

however, for large momenta, i.e. $R \tan \lambda \gg (z - z_0)$, assuming for simplicity $h = 1, \Phi_0 = 0$

$$y(z) \approx y_0 + \frac{1}{\tan \lambda} (z - z_0)$$

$$y(z) = y_0 + c \tan \lambda (z - z_0)$$

straight line

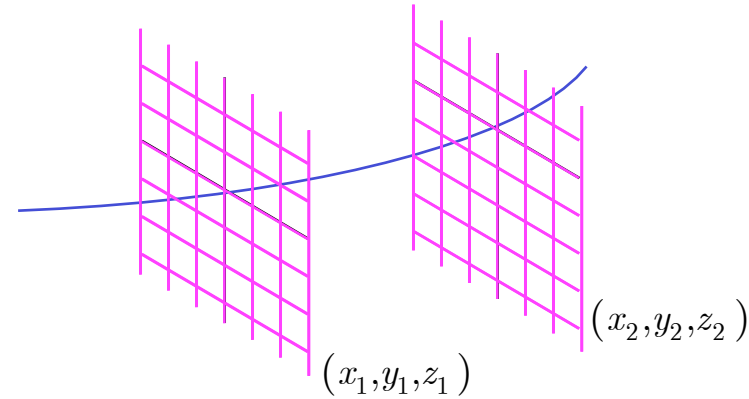

The Helix Equation

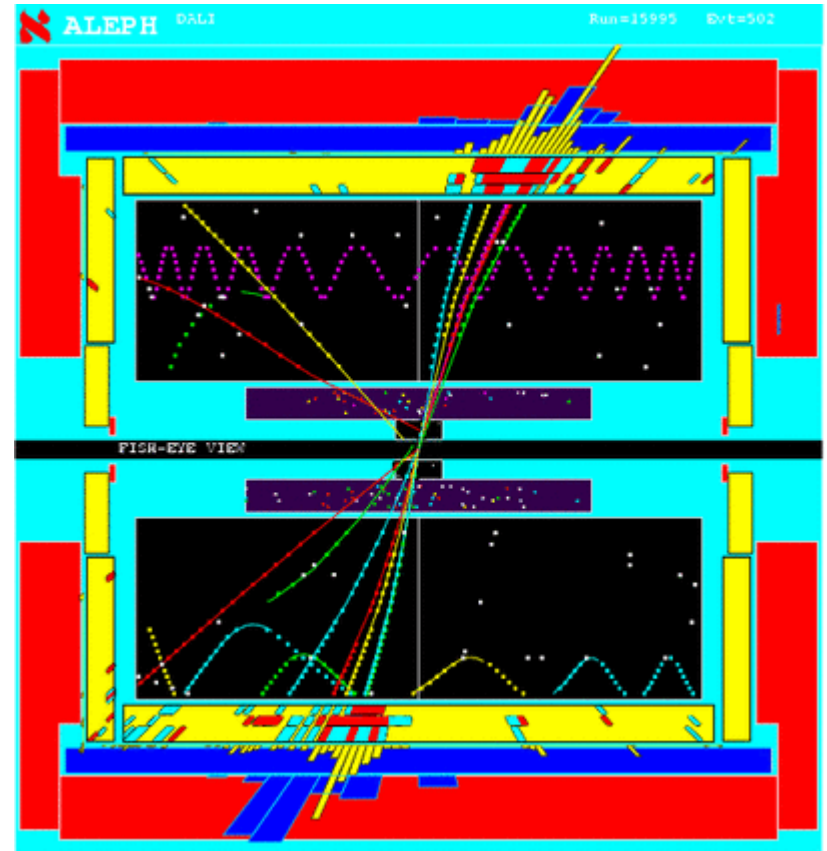
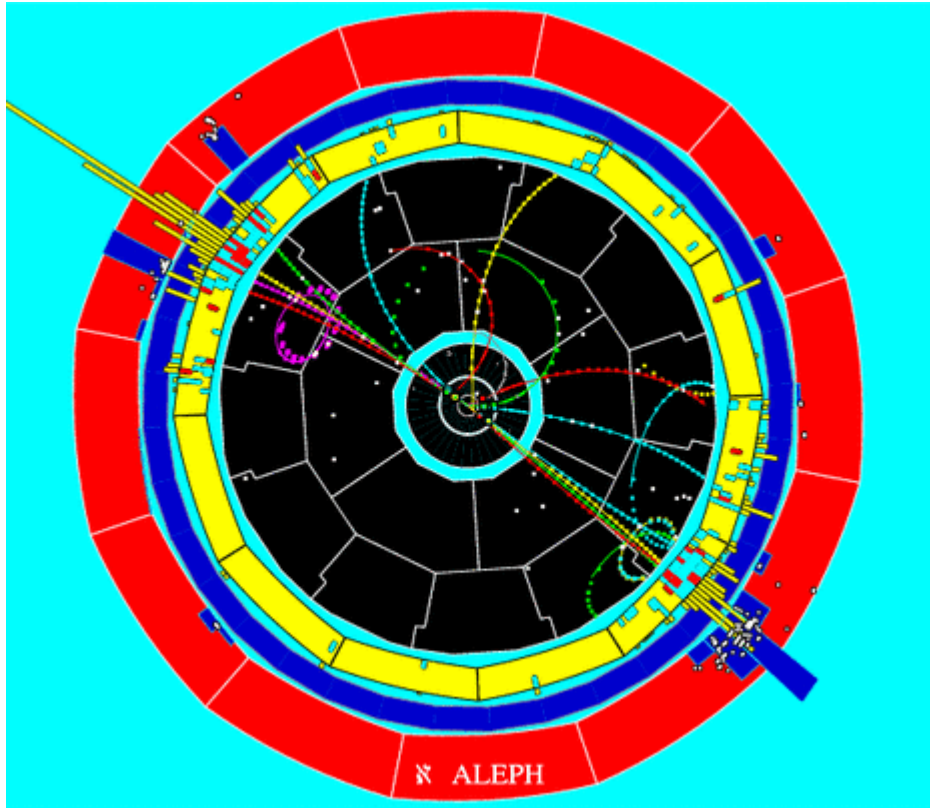

Straight Line Fit

This is a well known problem

a reference frame

$N+1$ measuring detectors at $z_0, \dots, z_n, \dots, z_N$

a particle crossing the detectors

$N+1$ coordinate measurements $y_0, \dots, y_n, \dots, y_N$

each measurement affected by uncorrelated errors $\sigma_0, \dots, \sigma_n, \dots, \sigma_N$

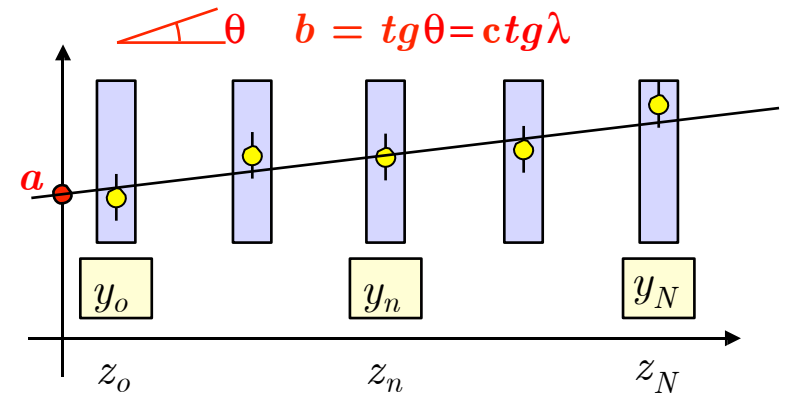

Find the best line $y = a + b z$ that fit the track

The solution is found by minimizing the χ^2

$$\chi^2 = \sum_{n=0}^N \frac{(y_n - a - bz_n)^2}{\sigma_n^2}$$

$$a = (S_y S_{zz} - S_z S_{zy}) / D$$

$$b = (S_1 S_{zy} - S_z S_y) / D$$

the covariance matrix (at $z = 0$) is

$$\begin{pmatrix} \sigma_a^2 & c_{ab} \\ c_{ab} & \sigma_b^2 \end{pmatrix} = \frac{1}{D} \begin{pmatrix} S_{zz} & -S_z \\ -S_z & S_1 \end{pmatrix}$$

depends only on σ, z_n and N

$$S_1 = \sum_{n=0}^N \frac{1}{\sigma_n^2}$$

$$S_y = \sum_{n=0}^N \frac{y_n}{\sigma_n^2}$$

$$S_z = \sum_{n=0}^N \frac{z_n}{\sigma_n^2}$$

$$S_{yz} = \sum_{n=0}^N \frac{y_n z_n}{\sigma_n^2}$$

$$S_{zz} = \sum_{n=0}^N \frac{z_n^2}{\sigma_n^2}$$

$$D = S_1 S_{zz} - S_z^2$$

Straight Line Fit: Matrix Formalism

It is useful to restate the problem using a matrix formalism [4:Avery 1991]

This is useful because:

it is more compact

it is easily extensible to other linear problems

it is more useful to formulate an iterative procedure

With the same assumption as before

the linear model is given by $\mathbf{f} = \mathbf{A}\mathbf{p}$

$$\mathbf{f} = \begin{pmatrix} f_0 \\ \dots \\ f_N \end{pmatrix} = \begin{pmatrix} a + bz_0 \\ \dots \\ a + bz_N \end{pmatrix} = \begin{pmatrix} 1 & z_0 \\ 1 & \dots \\ 1 & z_N \end{pmatrix} \begin{pmatrix} a \\ b \end{pmatrix} = \mathbf{A}\mathbf{p}$$

measurements and errors are

$$\mathbf{Y} = \begin{pmatrix} y_0 \\ \dots \\ y_N \end{pmatrix} \quad (\mathbf{V})_{ij} = \langle (y_i - \langle y_i \rangle)(y_j - \langle y_j \rangle) \rangle$$

$$(\mathbf{V})_{ij} = \sigma_i^2 \delta_{ij} \quad \text{if uncorrelated}$$

The χ^2 can be written as

$$\chi^2 = (\mathbf{Y} - \mathbf{A}\mathbf{p})^T \mathbf{W} (\mathbf{Y} - \mathbf{A}\mathbf{p}) \quad \mathbf{W} = \mathbf{V}^{-1}$$

The minimum χ^2 is obtained by

$$\tilde{\mathbf{p}} = (\mathbf{A}^T \mathbf{W} \mathbf{A})^{-1} \mathbf{A}^T \mathbf{W} \mathbf{Y}$$

The covariance matrix of the parameters is obtained from the measurements covariance matrix \mathbf{V}

$$\mathbf{V}_P = (\mathbf{A}^T \mathbf{V}^{-1} \mathbf{A})^{-1}$$

please notice ($N+1$ measurements, M parameters)

dimensions $\mathbf{A} = (N+1) \times M$

dimensions $\mathbf{V} = (N+1) \times (N+1)$

dimensions $\mathbf{A}^T \mathbf{W} \mathbf{A} = M \times M$

dimensions $\mathbf{A}^T \mathbf{W} = M \times (N+1)$

dimensions $\mathbf{V}_P = M \times M$

Straight Line Fit

Let's consider the case of equal spacing between z_0 and z_N with equal errors on coordinates $\sigma_n = \sigma$

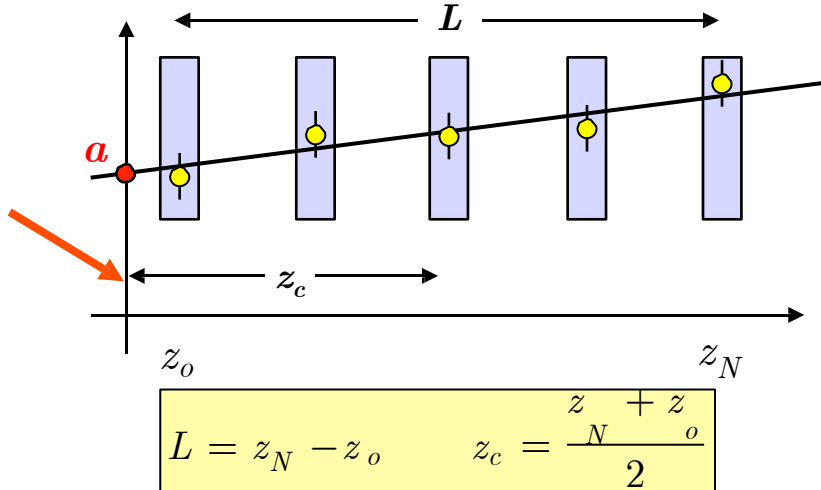

The S are easily computed in finite form

$$S_1 = \frac{N+1}{\sigma^2} \quad S_z = (N+1) \frac{z_c}{\sigma^2}$$

$$S_{zz} = \frac{N+1}{\sigma^2} \left[\frac{N+2}{N} \frac{L^2}{12} + z_c^2 \right]$$

$$D = \frac{L^2}{12\sigma^4} \left[\frac{(N+1)^2 (N+2)}{N} \right]$$

S and errors: all computed at $z = 0$

The errors on the intercept and the slope are

$$\sigma_a^2 = \left[1 + 12 \frac{N}{N+2} \frac{z_c^2}{L^2} \right] \frac{\sigma^2}{N+1}$$

$$\sigma_b^2 = \frac{\sigma^2}{(N+1)L^2} \frac{12N}{(N+2)}$$

important features:

both errors are linearly dependent on the measurement error σ

both errors decrease as $1/\sqrt{N+1}$

the error on the slope decrease as the inverse of the lever arm L

the error on the intercept increases if z_c increase

Errors At The Center Of The Track

We can choose the origin at the center of the track: $z = z_c$

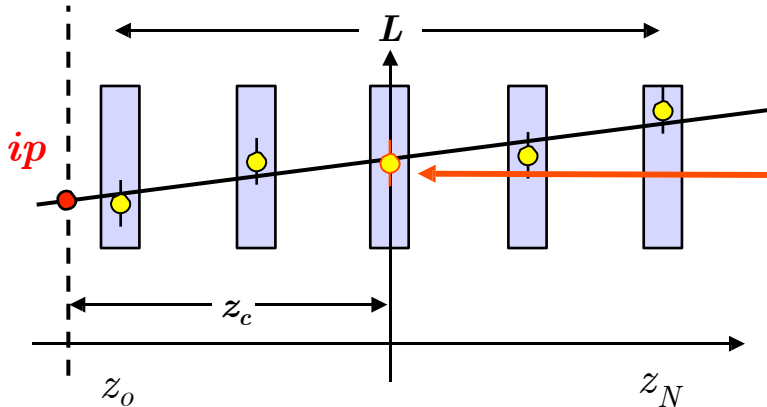

It is easily seen that for uniform spacing and equal errors

$$S_1 = \frac{N+1}{\sigma^2} \quad S_z = 0 \quad S_{zz} = \frac{N+1}{\sigma^2} \left[\frac{N+2}{N} \frac{L^2}{12} \right]$$

$$D = \frac{L^2}{12\sigma^4} \frac{(N+1)^2 (N+2)}{N}$$

S_1 and D do not change

S_z and S_{zz} change

The errors are now

$$\sigma_b^2 = \frac{\sigma^2}{(N+1)L^2} \frac{12N}{(N+2)} \quad \text{unchanged}$$

$$\sigma_a^2 = \frac{\sigma^2}{N+1} \quad \text{changed}$$

The intercept is different from the previous case (origin at $z = 0$)

Obviously, taking properly into account error propagation we get the same result for the impact parameter ip

$$ip = f(-z_c) = a - bz_c$$

$$\sigma_{ip}^2 = \sigma_a^2 + z_c^2 \sigma_b^2 \quad \sigma_a \text{ and } \sigma_b \text{ uncorrelated if origin at } z_c$$

$$\sigma_{ip}^2 = \frac{\sigma^2}{N+1} + \frac{\sigma^2}{N+1} \frac{12N}{N+2} \frac{z_c^2}{L^2}$$

Vertex Detectors

The previous result shows clearly the need for vertex detectors to achieve a precise measurements of the impact parameter

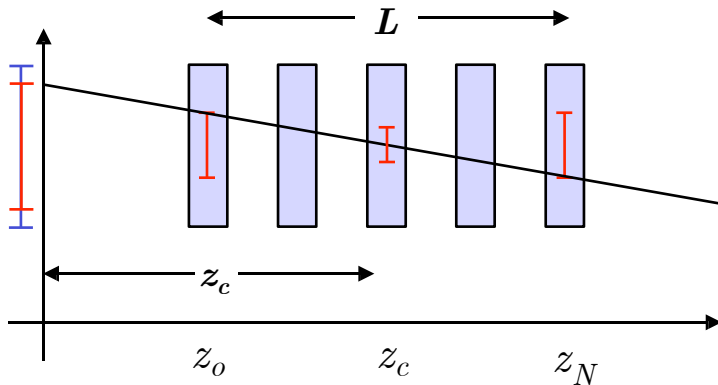

The “amplitude” of the error is determined

- by the error on the slope σ/L
- by the distance of the point to which we extrapolate z_c/L
- by the size of the measurement error

$$\sigma_{ip}^2 = \frac{\sigma^2}{N+1} + \frac{\sigma^2}{N+1} \frac{12N}{N+2} \frac{z_c^2}{L^2}$$

We should have

small measurement errors σ

large lever arm L

place first plane as near as possible to the production point: small z_c

Increasing the number of points also improves but only as $\sqrt{N+1}$

The technology used is silicon detectors with resolution of the order of $\sigma \sim 10 \mu\text{m}$

expensive

small N

small L

Vertex Detectors (before IBL insertion)

Summarizing: the error on the impact parameter is

$$\sigma_{ip} = Z(r, N) \frac{\sigma}{\sqrt{N+1}}$$

$$r = \frac{z_c}{L}$$

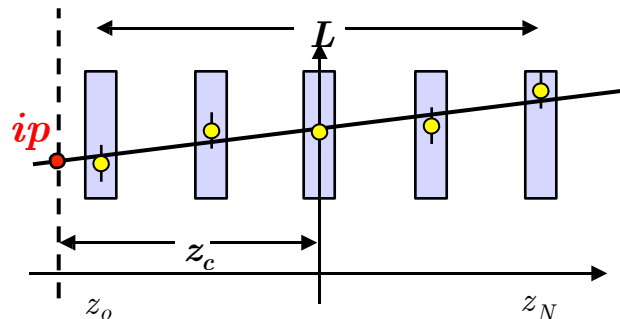

for the ATLAS pixel detector

$$N+1 = 3, \sigma = 10 \mu m$$

$$z_0 = 4.1 \text{ cm}, z_2 = 13.5 \text{ cm}$$

$$L = 9.4, z_c = 6.8, r = 0.72$$

$$\sigma_{ip} = 12 \mu$$

$$Z(r, N) = \sqrt{1 + 12 \frac{N}{N+2} r^2}$$

N	r	5.0	3.0	2.0	1.5	1.0	0.75	0.60	0.50
1		10.1	6.08	4.12	3.16	2.24	1.80	1.56	1.41
2		12.3	7.42	5.00	3.81	2.65	2.09	1.78	1.58
5		14.7	8.84	5.94	4.50	3.09	2.41	2.02	1.77
9		15.7	9.45	6.35	4.81	3.29	2.55	2.13	1.86
19		16.5	9.94	6.67	5.04	3.44	2.67	2.22	1.93
∞		17.3	10.4	7.00	5.29	3.61	2.78	2.31	2.00

Vertex Detector + Central Detector

We have seen that the error on the impact parameter is

$$\sigma_{ip}^2 = \sigma_a^2 + z_c^2 \sigma_b^2$$

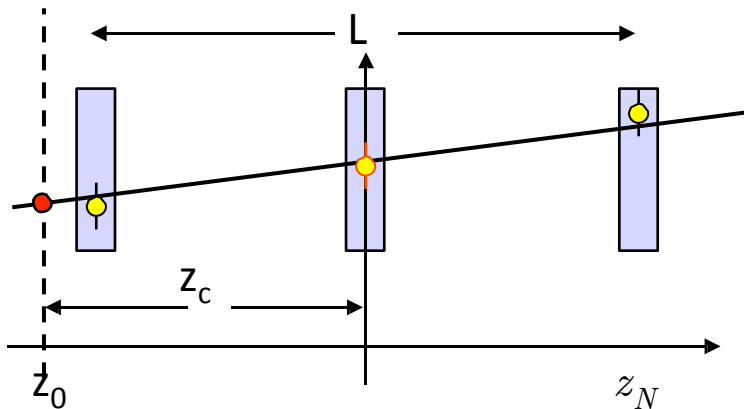

- The first term:
 - depend only on the precision of the vertex detector
- it is equivalent to a very precise measurement ($\sigma_a \sim 5 \mu$) very near to the primary vertex (z_c)

The second term depends on the error on the slope and is limited by the small lever arm L typical of vertex detectors ($\sim 10 \text{ cm}$)

It is usually very expensive to increase this lever arm

A solution is a bigger detector (Central Detector) less precise (usually less expensive) but with a much bigger lever arm L

The error on the slope then become smaller

The error on the extrapolation become smaller

This is the arrangement usually adopted by experiments who want to measure the impact parameter

Momentum Measurement: Sagitta

To introduce the problem of momentum measurement let's go back to the sagitta

a particle moving in a plane perpendicular to a uniform magnetic field B

$$R = \frac{p}{0.3B} \quad \frac{\delta p}{p} = \frac{\delta R}{R}$$

the trajectory of the particle is an arc of radius R of length L

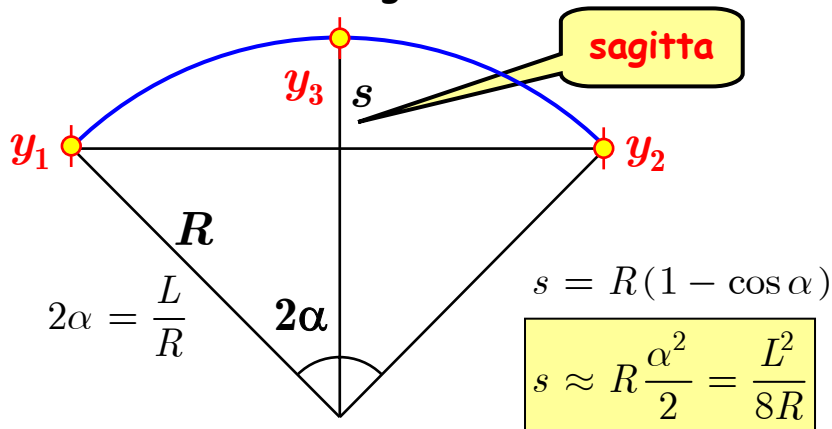

assume we have 3 measurements: y_1, y_2, y_3

$$s = y_3 - \frac{y_1 + y_2}{2} \quad \delta s = \sqrt{\frac{3}{2}} \delta y \sim \delta y$$

the error on the radius is related to the sagitta error by

$$|\delta s| = \frac{L^2}{8R} \frac{\delta R}{R} \sim \delta y \quad \frac{L^2}{8R} \frac{\delta p}{p} = \delta y$$

$$\frac{\delta p}{p} = \frac{8R}{L^2} \delta y \quad \frac{\delta p}{p} = \frac{8p}{0.3BL^2} \delta y$$

$$\frac{\delta p}{p^2} = \frac{8\delta y}{0.3BL^2}$$

important features

the percentage error on the momentum is proportional to the momentum itself

the error on the momentum is inversely proportional to B

the error on the momentum is inversely proportional to $1/L^2$

the error on the momentum is proportional to coordinate measurement error

Tracking In Magnetic Field

The previous example showed the basic features of momentum measurement

Let's now turn to a more complete treatment of the measurement of the charged particle trajectory

We have already seen that for an homogeneous magnetic field the trajectory projected on a plane perpendicular to the magnetic field is a circle

$$(y - y_o)^2 + (x - x_o)^2 = R^2$$

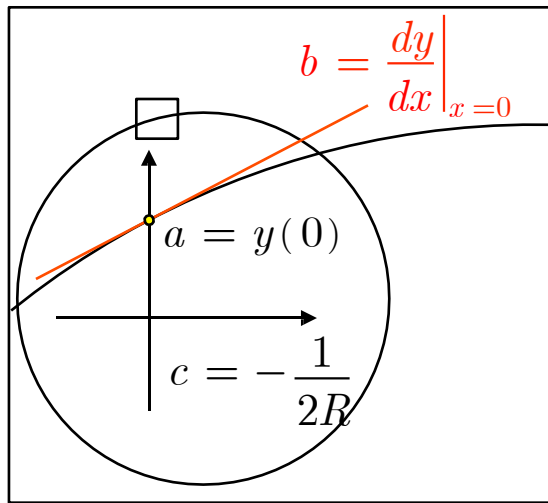

for not too low momenta we can use a linear approximation

$$y = y_o + \sqrt{R^2 - (x - x_o)^2}$$

$$y \approx y_o + R \left(1 - \frac{(x - x_o)^2}{2R^2} \right)$$

$$y = \left(y_o + R - \frac{x_o}{2R^2} \right) + \frac{x_o}{R} x - \frac{1}{2R} x^2$$

$$R^2 \gg (x - x_o)^2$$

we are led to the parabolic approximation of the trajectory

$$y = a + bx + cx^2$$

let's stress that as far as the track parameters is concerned the dependence is linear

The parameters a, b, c are

intercept **at the origin**

slope **at the origin**

radius **of curvature** (momentum)

Quadratic Fit

Assume N detectors measuring the y coordinate [Gluckstern 63]

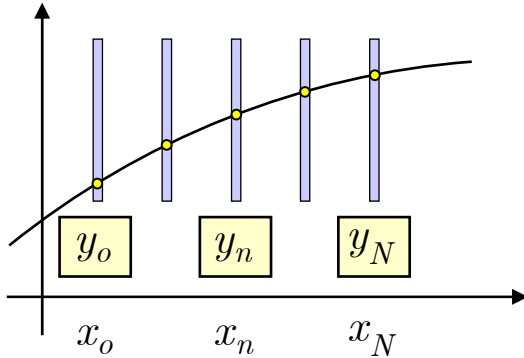

The detectors are placed at positions $x_0, \dots, x_n, \dots, x_N$

A track crossing the detectors

gives the measurements $y_0, \dots, y_n, \dots, y_N$

Each measurement has an error σ_n

Using the parabola approximation, the track parameters are found by minimizing the χ^2

$$\chi^2 = \sum_{n=0}^N \frac{(y_n - a - bx_n - cx_n^2)^2}{\sigma_n^2}$$

However we can use the matrix formalism developed for the straight line:

$$\mathbf{Y} = \begin{pmatrix} y_0 \\ \dots \\ y_N \end{pmatrix} \quad \mathbf{p} = \begin{pmatrix} a \\ b \\ c \end{pmatrix} \quad \mathbf{A} = \begin{pmatrix} 1 & x_0 & x_0^2 \\ \dots & \dots & \dots \\ 1 & x_N & x_N^2 \end{pmatrix} \quad \mathbf{W} = \begin{pmatrix} \frac{1}{\sigma_0^2} & 0 & 0 \\ 0 & \dots & \dots \\ 0 & 0 & \frac{1}{\sigma_N^2} \end{pmatrix}$$

let's recall the solution

$$\tilde{\mathbf{p}} = (\mathbf{A}^T \mathbf{W} \mathbf{A})^{-1} \mathbf{A}^T \mathbf{W} \mathbf{Y}$$

$$(\mathbf{A}^T \mathbf{W} \mathbf{A})^{-1} = \begin{pmatrix} F_0 & F_1 & F_2 \\ F_1 & F_2 & F_3 \\ F_2 & F_3 & F_4 \end{pmatrix}^{-1} \quad F_k = \sum_{n=0}^N \frac{x_n^k}{\sigma_n^2}$$

$$\mathbf{A}^T \mathbf{W} \mathbf{Y} = \begin{pmatrix} M_0 \\ M_1 \\ M_2 \end{pmatrix} \quad M_k = \sum_{n=0}^N \frac{y_n x_n^k}{\sigma_n^2}$$

Quadratic Fit

The result is [4: Avery 1991, Blum-Rolandi 1993 p.204, Gluckstern 63]

$$a = \frac{\sum y_n G_n}{\sum G_n} \quad b = \frac{\sum y_n x_n G_n}{\sum x_n G_n} \quad c = \frac{\sum y_n x_n^2 G_n}{\sum x_n^2 G_n}$$

$$G_n = F^{11} - x_n F^{21} + x_n^2 F^{31}$$

$$P_n = -F^{12} + x_n F^{22} - x_n^2 F^{32}$$

$$Q_n = F^{13} - x_n F^{23} + x_n^2 F^{33}$$

The quantities F^{ij} are the determinants of the 2x2 matrices obtained from the 3x3 matrix F by removing row i , column j

The covariance matrix

$$\mathbf{V}_p = (\mathbf{A}^T \mathbf{W} \mathbf{A})^{-1} = \begin{pmatrix} F_0 & F_1 & 2 \\ F_1 & F_2 & F_3 \\ F_2 & F_3 & F_4 \end{pmatrix}^{-1}$$

The result can be found in [Blum-Rolandi, p. 206]

To get some idea of the covariance matrix let's first compute it by setting the origin at the center of the track

$$x_c = \sum_{n=0}^N \frac{x_n}{N+1}$$

with this choice one can "easily" find

$$F_1 = F_3 = 0$$

$$F_0 = \frac{N+1}{\sigma^2}$$

$$F_2 = \frac{L^2 (N+1)(N+2)}{\sigma^2 12N}$$

$$F_4 = \frac{L^4 (N+1)(N+2)(3N^2 + 6N - 4)}{\sigma^2 240N^3}$$

$$S = F_0 F_4 - F_2^2 = \frac{L^4 (N-1)(N+1)^2 (N+2)(N+3)}{\sigma^4 180N^3}$$

Momentum Resolution

The covariance matrix is

$$\mathbf{V}_p = \frac{1}{F_0 F_4 - F_2 F_2} \begin{pmatrix} F_4 & 0 & -F_2 \\ 0 & \frac{F_0 F_4 - F_2 F_2}{F_2} & 0 \\ -F_2 & 0 & F_0 \end{pmatrix}$$

we are mostly interested on the error on the curvature

$$\sigma_c^2 = \frac{F_0}{F_0 F_4 - F_2 F_2} = \frac{\sigma^2}{L^4} C_N$$

$$C_N = \frac{180N^3}{(N-1)(N+1)(N+2)(N+3)}$$

it can be shown that the error on the curvature do not depend on the position of the origin along the track

Let's recall from the discussion on the sagitta

$$R = \frac{p}{0.3B} \quad \frac{\delta p}{p} = \frac{\delta R}{R}$$

also recall that

$$c = \frac{1}{2R} \quad \sigma_c = \frac{1}{2R^2} \delta R$$

and finally the momentum error

$$\frac{\delta p}{p^2} = \frac{\sigma}{0.3BL^2} \sqrt{4C_N}$$

the formula shows the same basic features we noticed in the sagitta discussion

we have also found the dependence on the number of measurements (weak)

Momentum Resolution

We stress again that a good momentum resolution call for a long track

$$\frac{\delta p}{p^2} \sim \frac{1}{L^2}$$

any trick that can extend the track length can produce significant improvements on the momentum resolution

the use of the vertex can also improve momentum resolution:

the common vertex from which all the tracks originate can be fitted

the point found can be added to every track to extend the track length at

$$R_{min} \rightarrow 0$$

the position of the beam spot can also be used as constraint

Extending R_{max} can be very expensive

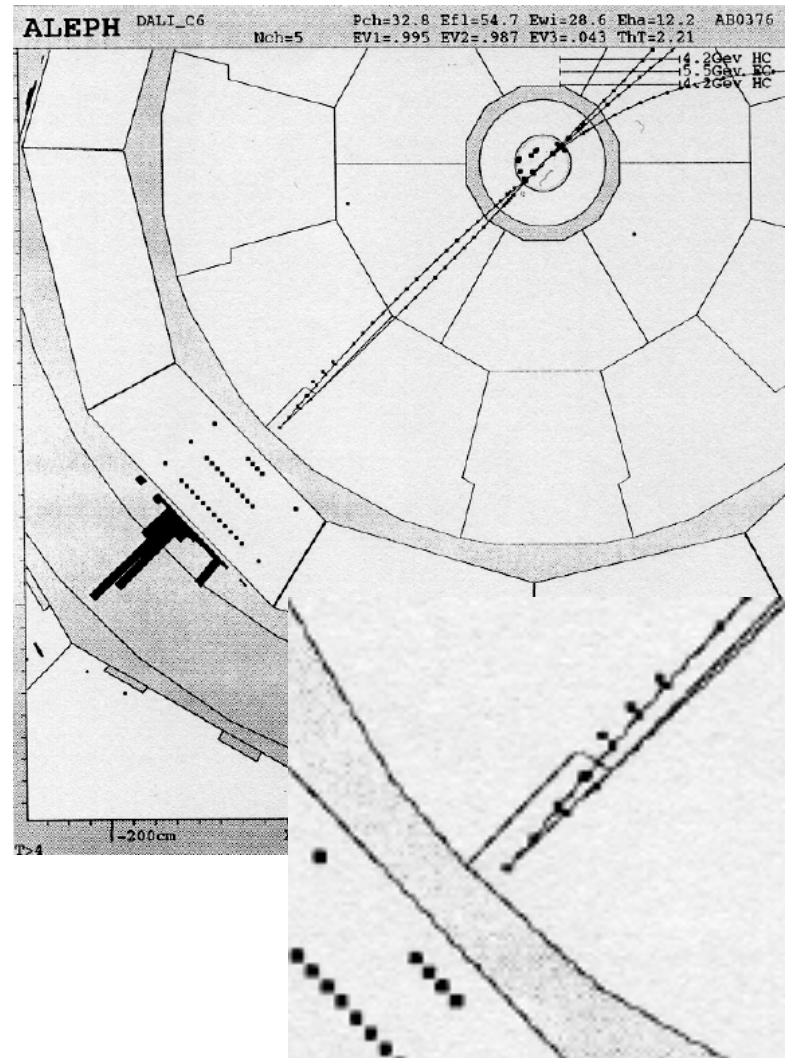

Momentum Resolution

We can now give a rough estimate of the momentum resolution of the ATLAS tracking systems

There are different systems: some simplifying guess

TRT: 36 point with $\sigma = 170 \mu m$ from 55 cm to 105 cm: as a single point with $\sigma = 28 \mu m$ at $R_{max} = 80 \text{ cm}$

$R_{min} = 4.7 \text{ cm}$, $L = 75 \text{ cm}$

$N+1 = 3 + 4 + 1 = 8$

$\sigma = 12, 16, 28 \sim 20 \mu m$

$$C_N \approx 12 \quad \sqrt{4C_N} \approx 7$$

$$\frac{\delta p}{p^2} \sim 4 \times 10^{-4} \text{ GeV}^{-1}$$

At 500 GeV $\frac{\delta p}{p} = 20 \times 10^{-2}$

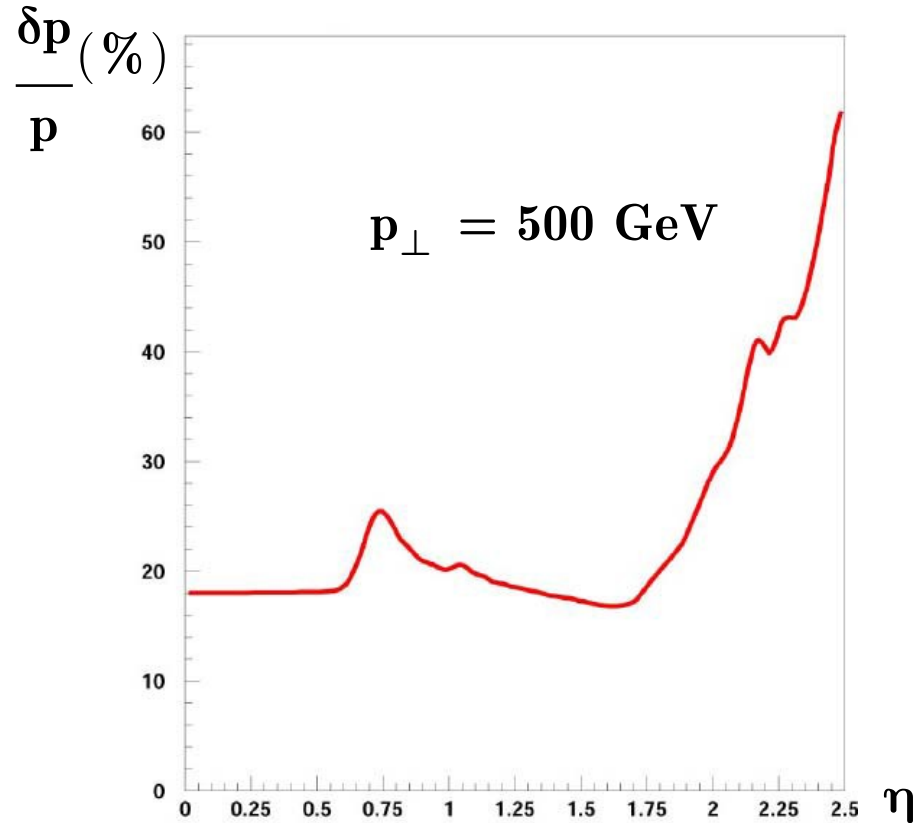

Momentum Resolution

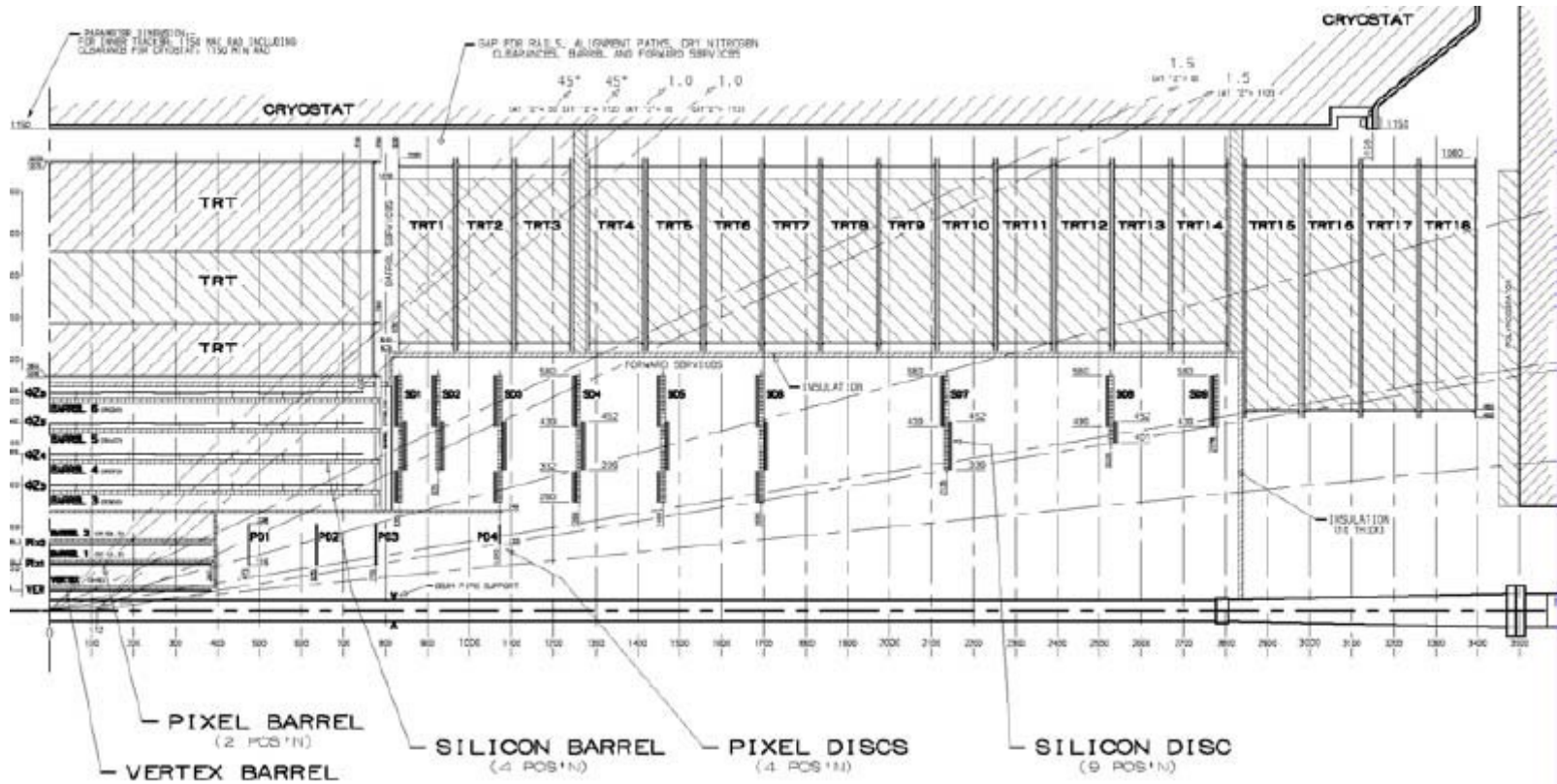

Slope And Intercept Resolution

For completeness we give also the errors on the slope and intercept

The error on the slope is given by

$$\sigma_b^2 = \frac{1}{F_2} = B_N \frac{\sigma^2}{L^2}$$

$$B_N = \frac{12N}{(N+1)(N+2)}$$

We find the same qualitative behaviour we had for the straight line fit

The error on the intercept is

$$\sigma_a^2 = \frac{F_4}{F F_0 - F_2 F_2} = A_N \sigma^2$$

$$A_N = \frac{3(3N^2 + 6N - 4)}{4(N-1)(N+1)(N+3)}$$

The only off diagonal element of the covariance matrix different from 0 is between intercept and curvature and we have

$$\sigma_{ac} = -\frac{F_2}{F F_0 - F_2 F_2} = -D_N \frac{\sigma^2}{L^2}$$

$$D_N = -\frac{15N^2}{(N-1)(N+1)(N+3)}$$

Extrapolation To Vertex

We want now compute the extrapolation to vertex and compare the behaviour of the results of the fit:

inside magnetic field

no magnetic field

having measured the parameters a, b, c at the center of the track, the intercept is

$$y_{ip} = a + bx_v + cx_v^2$$

Propagation of the errors gives

$$\sigma_{ip}^2 = \sigma_a^2 + x_v^2 \sigma_b^2 + x_v^4 \sigma_c^2 + 2x_v^2 \sigma_{ac}$$

The calculation gives [Blum-Rolandi 1993]

$$\sigma_{ip} = \frac{\sigma}{\sqrt{N+1}} B_{aa}(r, N)$$

where $B_{aa}(r, N)$ is analogous to $Z(r, N)$ defined for the straight line fit (see next slide for a table of values)

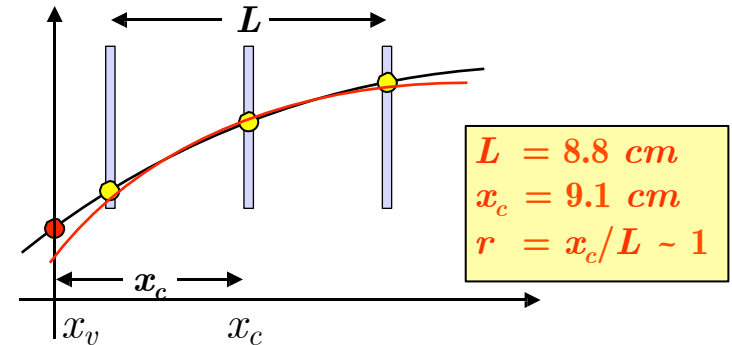

let's compare the error assuming the geometry of the ATLAS pixel detector:

$$R_{min} = 4.7, R_{max} = 13.5, N+1 = 3$$

we have $r = 1$ and from the 2 tables we get

$$B_{aa}(1,2) = 7.63$$

$$Z(1,2) = 2.65$$

We see that the error is degraded by a factor ~ 2.9

The reason is that the error on momentum cause an additional contribution to the error in the extrapolation

a central tracking detector is needed



Extrapolation To Vertex

$$\sigma_{ip} = \frac{\sigma}{\sqrt{N+1}} B_{aa}(r, N)$$

$$B_{aa}(r, N)$$

N	r	5.0	3.0	2.0	1.5	1.0	0.75	0.60	0.50
2		211	75/3	32.9	18.1	7.63	4.10	2.65	2.05
3		224	80.2	35.2	19.5	8.29	4.48	2.84	2.07
5		250	89.5	39.4	21.9	9.39	5.10	3.20	2.26
10		282	101	44.6	24.8	10.7	5.84	3.65	2.54
19		304	109	48.1	26.8	11.6	6.32	3.95	2.72
∞		335	120	53.0	29.5	12.8	7.00	4.37	3.00



Parameters Propagation

We have seen that changing the origin of the reference frame

the track parameters change
the covariance matrix changes

It is often useful to propagate the parameters describing the track from one "origin" (point 0) to "another" (point 1)

For linear models this is very easily expressed in matrix form

$$\mathbf{p}_i = \mathbf{f}_i(\mathbf{p}_k) = \mathbf{D}_i \mathbf{p}_k \quad \mathbf{D}_i = \frac{\partial \mathbf{f}_i}{\partial \mathbf{p}_k}$$

To better understand the above formulas let's apply them to the straight line and to the parabola

straight line

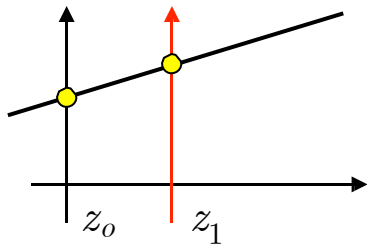

$$\mathbf{p}_0 = \begin{pmatrix} a \\ b \end{pmatrix}$$

$$\mathbf{p}_1 = \begin{pmatrix} a + bz_1 \\ b \end{pmatrix}$$

$$\frac{\partial \mathbf{f}_1}{\partial \mathbf{p}_0} = \frac{\partial \mathbf{p}_1}{\partial \mathbf{p}_0} = \begin{pmatrix} 1 & z_1 \\ 0 & 1 \end{pmatrix}$$

parabola

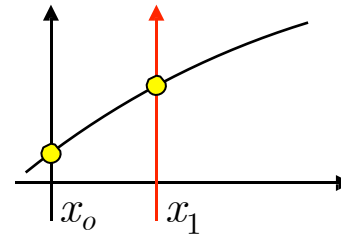

$$\mathbf{p}_0 = \begin{pmatrix} a \\ b \\ c \end{pmatrix}$$

$$\mathbf{p}_1 = \begin{pmatrix} a + bx_1 + cx_1^2 \\ b + 2cx_1 \\ c \end{pmatrix}$$

$$\frac{\partial \mathbf{f}_1}{\partial \mathbf{p}_0} = \frac{\partial \mathbf{p}_1}{\partial \mathbf{p}_0} = \begin{pmatrix} 1 & x_1 & x_1^2 \\ 0 & 1 & 2x_1 \\ 0 & 0 & 1 \end{pmatrix}$$

Using the matrix D we can also propagate the covariance matrix of the parameters

$$\mathbf{V}_1 = (\mathbf{D}^T \mathbf{V}_0^{-1} \mathbf{D})^{-1}$$

Multiple Scattering

Particles moving through the detector material suffer innumerable EM collisions which alter the trajectory in a random fashion (stochastic process)

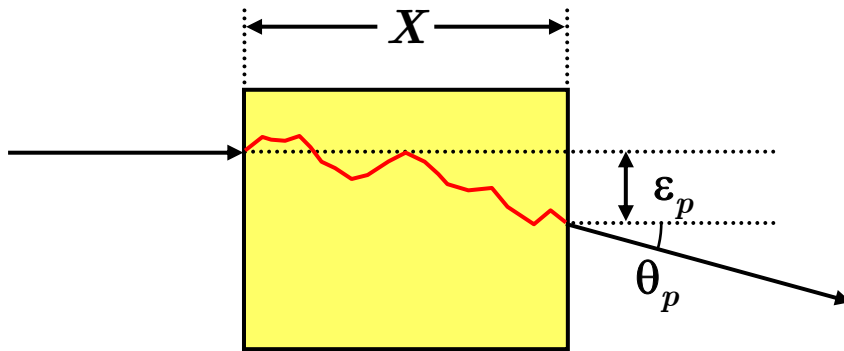

Few examples:

Argon $X_o = 110 \text{ m}$

Silicon $X_o = 9.4 \text{ cm}$

consider a 10 GeV pion

		θ_p	ϵ_p
Argon:	1 m	0.10×10^{-3}	80 μm
Silicon:	300 μm	0.08×10^{-3}	0.01 μm

The effect goes as $1/p$: for a pion of 1 GeV the effect is 10 times larger

The lateral displacement is proportional to the thickness of the detector: usually can be neglected for thin detectors

In what follow we will consider only thin detectors

For thick detectors (for example large volume gas detectors) see [Gluckstern 63 Blum-Rolandi 93, Block et al. 90]

$$\langle \theta_p^2 \rangle = K \frac{X}{X_0}$$

$$K = z^2 \left(\frac{0.0136}{p\beta} \right)^2$$

$$\langle \epsilon_p^2 \rangle = \frac{1}{3} K \frac{X}{X_0} X^2$$

strongly correlated

$$\langle \epsilon_p \theta_p \rangle = \frac{1}{2} K \frac{X}{X_0} X \quad \rho = \frac{\langle \epsilon_p \theta_p \rangle}{\sqrt{\langle \epsilon_p^2 \rangle \langle \theta_p^2 \rangle}} = 0.87$$

Multiple Scattering

The scattering angle has a distribution that is almost gaussian

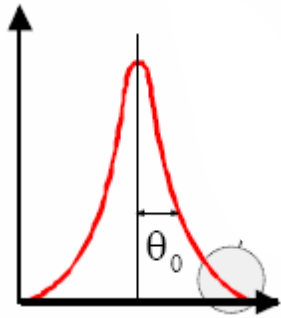

$$\frac{1}{\sin^4 \frac{\theta_p}{2}}$$

$$P(\theta_p) = \frac{1}{\sqrt{2\pi \langle \theta_p^2 \rangle}} \exp \left[-\frac{1}{2 \langle \theta_p^2 \rangle} \theta_p^2 \right]$$

$$\langle \theta_p^2 \rangle = K \frac{X}{X_0}$$

$$K = z^2 \left(\frac{0.0136}{p\beta} \right)^2$$

At large angles deviations from gaussian distributions appear that manifest as a long tail going as $\sin^{-4}\theta/2$

In thick detectors the distribution of the lateral displacement should also be considered

The joint distribution of the scattering angle and the lateral displacement is

$$P(\varepsilon_p, \theta_p) = \frac{\sqrt{3}}{\pi \langle \theta_p^2 \rangle X^2} \exp \left[-\frac{2}{\langle \theta_p^2 \rangle} \left(\theta_p^2 - \frac{3\varepsilon_p \theta_p}{X} + \frac{3\varepsilon_p^2}{X^2} \right) \right]$$

Multiple Scattering

Multiple scattering is a cumulative effect and introduces correlation among the coordinate measurements

The treatment of multiple scattering is different for:

discrete detectors

continuous detectors

Here we consider only the simplest case of discrete and thin detectors

For continuous detectors see for example [5: Avery 1991]

Let's consider 3 thin detectors

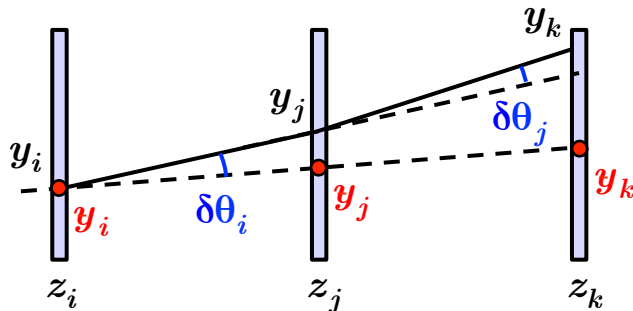

A track crosses the 3 planes at positions

$$y_i \quad y_j \quad y_k$$

The 3 coordinates have measurement errors $\sigma_i, \sigma_j, \sigma_k$ due to the detector resolution

They also have mean value

$$\langle y_i \rangle = \bar{y}_i \quad \langle y_j \rangle = \bar{y}_j \quad \langle y_k \rangle = \bar{y}_k$$

on plane i $y_i = y_i$

Because of multiple scattering on plane i the actual trajectory crosses plane j at

$$y_j = y_j + (z_j - z_i) \delta\theta_i$$

Because of multiple scattering on planes i, j the actual trajectory crosses plane k at

$$y_k = y_k + (z_k - z_i) \delta\theta_i + (z_k - z_j) \delta\theta_j$$

Since $\langle \delta\theta \rangle = 0$

$$\bar{y}_i = \bar{y}_i \quad \bar{y}_j = \bar{y}_j \quad \bar{y}_k = \bar{y}_k$$

Multiple Scattering

we can now compute the covariance matrix of the coordinate measurements including multiple scattering

$$V_{nm} = \langle (y_m - \bar{y}_m)(y_n - \bar{y}_n) \rangle$$

First the diagonal elements

$$V_{ii} = \langle (y_i - \bar{y}_i)^2 \rangle = \langle (y_i - \tilde{y}_i)^2 \rangle$$

$$V_{ii} = \sigma_i^2$$

$$\begin{aligned} V_{jj} &= \langle (y_j - \bar{y}_j)^2 \rangle = \langle (y_j - \tilde{y}_j + (z_j - z_i)\delta\theta_i)^2 \rangle \\ &= \langle (y_j - \tilde{y}_j)^2 \rangle + (z_j - z_i)^2 \langle \delta\theta_i^2 \rangle + 2(z_j - z_i) \langle (y_j - \tilde{y}_j)\delta\theta_i \rangle \end{aligned}$$

$$V_{jj} = \sigma_j^2 + (z_j - z_i)^2 \langle \delta\theta_i^2 \rangle$$

it easy to verify that

$$V_{kk} = \sigma_k^2 + (z_k - z_i)^2 \langle \delta\theta_i^2 \rangle + (z_k - z_j)^2 \langle \delta\theta_j^2 \rangle$$

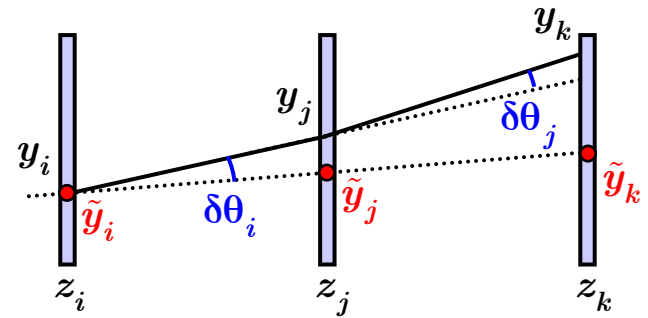

Multiple Scattering

$$V_{nm} = \langle (y_m - \bar{y}_m)(y_n - \bar{y}_n) \rangle$$

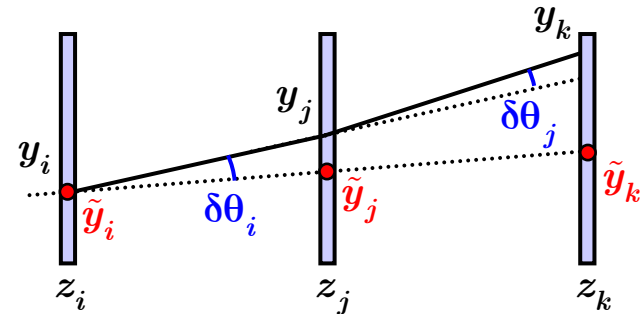

The off-diagonal elements are

$$V_{ij} = \langle (y_i - \bar{y}_i)(y_j - \bar{y}_j) \rangle = \langle (y_i - \tilde{y}_i)(y_j - \tilde{y}_j + (z_j - z_i)\delta\theta_i) \rangle \quad V_{ij} = 0$$

$$V_{ik} = \langle (y_i - \bar{y}_i)(y_k - \bar{y}_k) \rangle \quad \text{uncorrelated: } \langle \rangle = 0$$

$$= \langle (y_i - \tilde{y}_i)(y_k - \tilde{y}_k + (z_k - z_i)\delta\theta_i + (z_k - z_j)\delta\theta_j) \rangle \quad V_{ik} = 0$$

$$V_{jk} = \langle (y_j - \bar{y}_j)(y_k - \bar{y}_k) \rangle \quad \text{uncorrelated: } \langle \rangle = 0$$

$$= \langle (y_j - \tilde{y}_j + (z_j - z_i)\delta\theta_i)(y_k - \tilde{y}_k + (z_k - z_i)\delta\theta_i + (z_k - z_j)\delta\theta_j) \rangle$$

$$= \langle (z_j - z_i)\delta\theta_i(z_k - z_i)\delta\theta_i \rangle$$

$$V_{jk} = (z_j - z_i)(z_k - z_i)\langle \delta\theta_i^2 \rangle$$

Multiple Scattering

Summarizing, the covariance matrix is

$$V = \begin{pmatrix} \sigma_i^2 & 0 & 0 \\ 0 & \sigma_j^2 & 0 \\ 0 & 0 & \sigma_k^2 \end{pmatrix} + \begin{pmatrix} 0 & 0 & 0 \\ 0 & (z_j - z_i)^2 \delta\theta_i^2 & (z_k - z_i)(z_j - z_i) \delta\theta_i^2 \\ 0 & (z_k - z_i)(z_j - z_i) \delta\theta_i^2 & (z_k - z_i)^2 \delta\theta_i^2 + (z_j - z_i)^2 \delta\theta_j^2 \end{pmatrix}$$

The second matrix has

diagonal elements due to any previous material affecting the trajectory impact point at the given plane

off diagonal elements: only presents if a previous material layer affects at the same time the trajectory impact points for the 2 planes

the same scattering at plane i

affects the trajectory at plane j and plane k

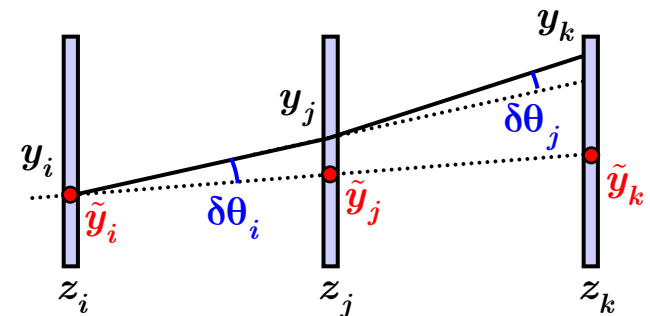

Track Fit With Multiple Scattering

The methods developed to fit a track to the measured points can be used to perform a fit taking into account M.S.

the covariance matrix is computed

the same fit procedure is applied

Let's now try to understand qualitatively the effect of multiple scattering on the determination of tracks parameters:

the size of the effect goes as $1/p$
then the effect is important for low momentum track

Assume we are dominated by multiple scattering

the momentum resolution is given by

$$\frac{\delta p}{p^2} = \frac{\sigma}{0.3BL^2} \sqrt{4A_N}$$

the coordinate error due to M.S. is

$$\sigma \sim \frac{L}{N} \delta\theta = \frac{L}{N} \frac{0.0136}{p\beta} \sqrt{\frac{X}{X_0}}$$

we have then

$$\frac{\delta p}{p} \sim \frac{0.0136}{\beta} \sqrt{\frac{X}{X_0}} \frac{1}{0.3BL} \frac{\sqrt{4A_N}}{N}$$

We conclude:

for low momentum the percentage momentum resolution reach a almost constant value (still dependent on β)

$$\frac{\delta p}{p} \rightarrow \text{constant}$$

The momentum resolution only improves as $1/L$

The additional factor $1/N$ can help but in this case uniform spacing is essential

Momentum Resolution with M.S.

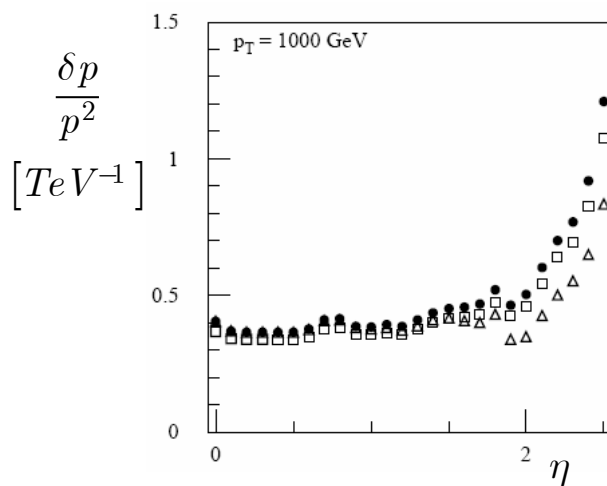
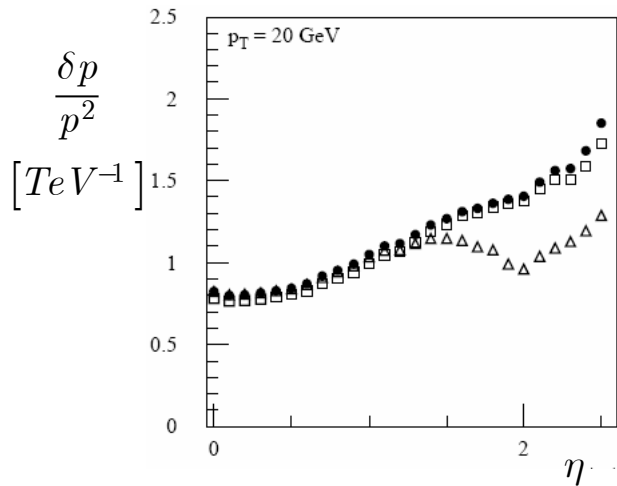
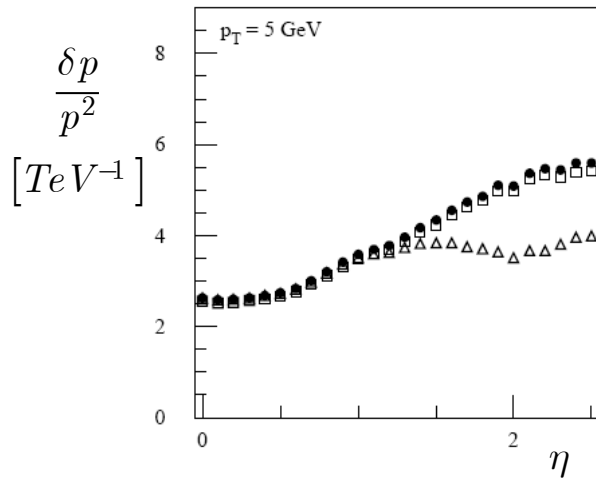
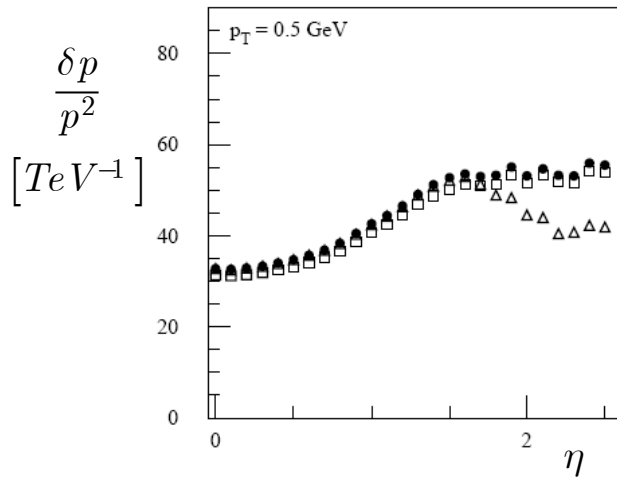

- solenoidal field
no beam constraint
- solenoidal field
with beam constraint
- △ uniform field
no beam constraint

Track Fit With Multiple Scattering

Same kind of considerations for the error on the slope and on the intercept
the multiple scattering error is

$$\sigma \sim \frac{L}{N} \delta\theta = \frac{L}{N} \frac{0.0136}{p\beta} \sqrt{\frac{X}{X_o}}$$

the error on the slope is

$$\sigma_b = \sqrt{B_N} \frac{\sigma}{L}$$
$$\sigma_b = \sqrt{B_N} \frac{L}{LN} \frac{0.0136}{p\beta} \frac{X}{X_o}$$

$$\sigma_b = \frac{\sqrt{B_N}}{N} \frac{0.0136}{p\beta} \sqrt{\frac{X}{X_o}}$$

we cannot improve anymore the error on the slope (direction) by increasing the lever arm

the limit is set by the multiple scattering angle itself

As far as the impact parameter resolution

$$\sigma_{ip} = \frac{\sigma}{\sqrt{N+1}} B_{aa}(r, N)$$

$$\sigma_{ip} = \frac{B_{aa}(r, N)}{\sqrt{N+1}} \frac{L}{N} \frac{0.0136}{p\beta} \sqrt{\frac{X}{X_o}}$$

large lever arm degrade the impact parameter resolution

for a given error on the slope set by the multiple scattering angle the error on the extrapolation goes as the lever arm

Unfortunately both ATLAS and CMS have a lot of material

silicon detectors for high precision

silicon for radiation hardness

silicon for rate capabilities

Material in ATLAS

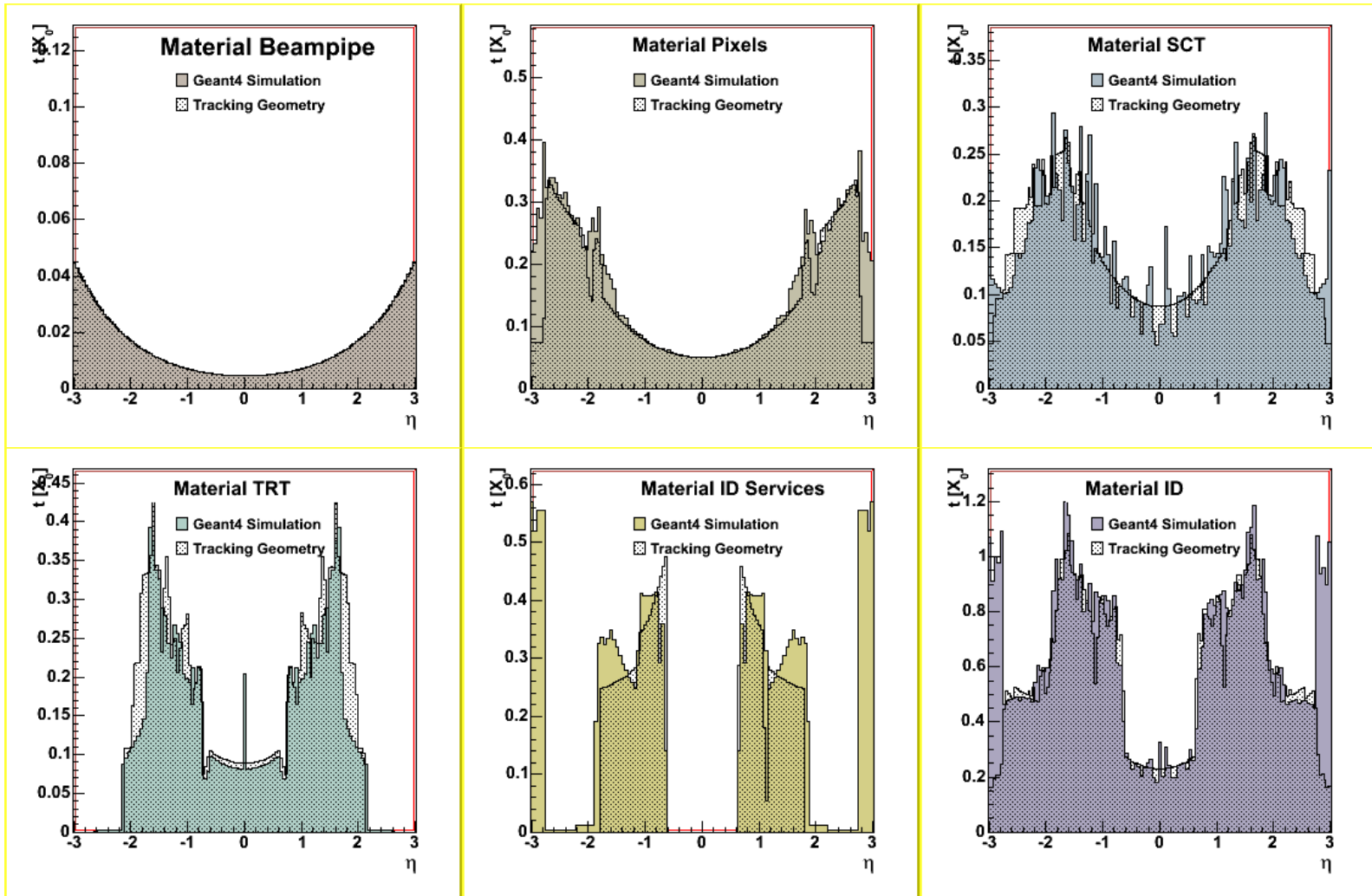

ATLAS

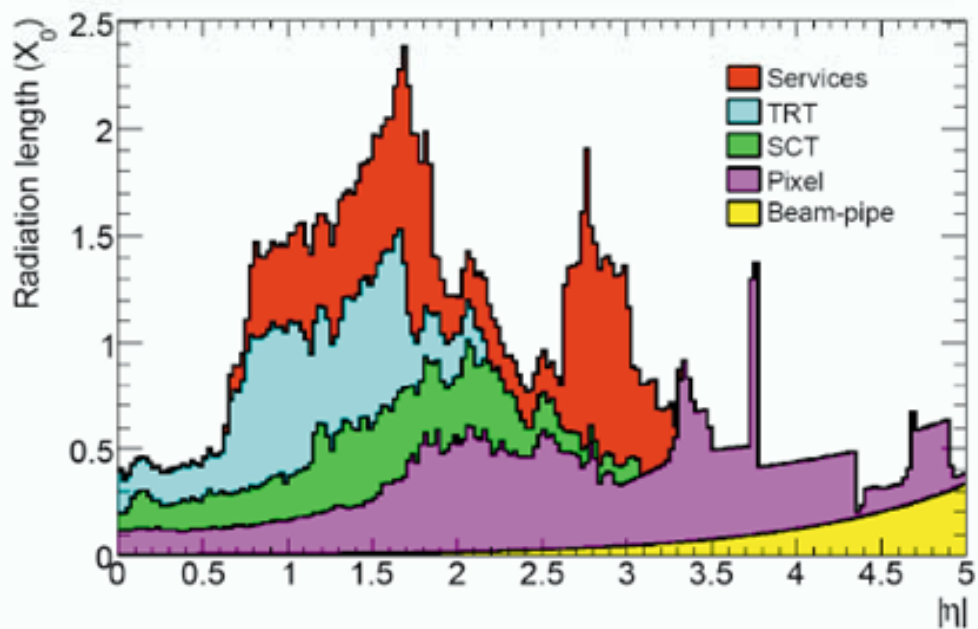

$ \eta $	radiation length	interaction length
< 1	$\sim 0.2 X_0$	$\sim 0.05 \lambda$
< 3.3	$\lesssim 0.5 X_0$	$\lesssim 0.2 \lambda$

Tracker Resolutions With M.S.

We have seen that for low momentum track the momentum resolution and the impact parameter resolution are dominated by multiple scattering

the momentum resolution tend to

$$\frac{\delta p}{p^2} \rightarrow \frac{k_p}{p} \sqrt{\frac{X}{X_0}} \quad \frac{\delta p}{p^2} \rightarrow \frac{K_p}{p\sqrt{\sin \theta}}$$

the impact parameter resolution tend to

$$\sigma_{ip} \rightarrow \frac{k_{ip}}{p} \sqrt{\frac{X}{X_0}} \quad \sigma_{ip} \rightarrow \frac{K_{ip}}{p\sqrt{\sin \theta}}$$

The amount of material actually traversed by the particles depend on the polar angle

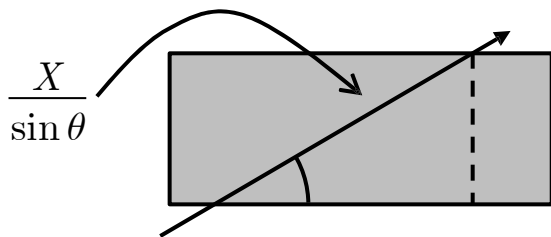

Since the multiple scattering error and the measurement error are independent to total error is sum in quadrature of the 2 term

For the ATLAS detector montecarlo studies have shown that the resolutions can be parametrised as

$$\sigma_{ip} = 11 \oplus \frac{73}{p_{\perp} \sqrt{\sin \theta}} \quad [\mu m]$$

$$\frac{\delta p_{\perp}}{p_{\perp}^2} = 0.00036 \oplus \frac{0.013}{p_{\perp} \sqrt{\sin \theta}} \quad [GeV^{-1}]$$

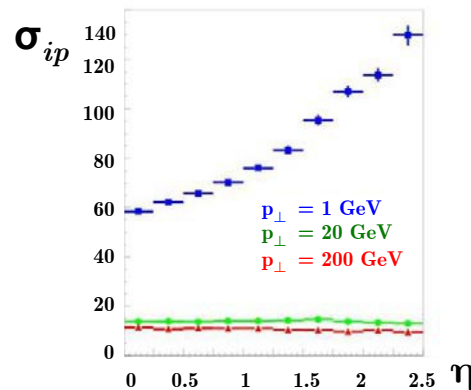

Sign Of The Charge

The sign of the charge is defined by the sign of $1/R$

$$Q = +1 \quad \frac{1}{R} > 0$$

$$Q = -1 \quad \frac{1}{R} < 0$$

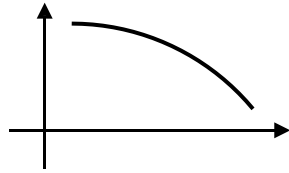
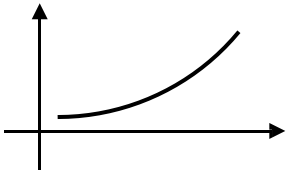

This measurement becomes more and more difficult as the momentum increases

Let's find up to which momentum the ATLAS tracker will be able to measure the sign of a charged particle

We recall that the error on the radius as determined from the parabola fit is

$$\sigma_c^2 = \frac{\sigma^2}{L^4} C_N$$

We remember that in our example we had

$$C_N = 12, L = 75 \text{ cm}, s = 20 \mu$$

if we require a 3σ identification

$$\frac{1}{R} > 3\sigma = 6\sigma_c = \frac{3\sigma_y}{L^2} \sqrt{4C_N}$$

$$\frac{1}{0.3BR} > \frac{3\sigma_y}{0.3BL^2} \sqrt{4C_N}$$

$$p < \frac{0.3BL^2}{3\sqrt{4C_N}\sigma_y}$$

inserting numerical values we find

$$p < 800 \text{ GeV}$$

Systematic Effects

Recall the formulas we found for the parabola fit

$$a = \frac{\sum y_n G_n}{\sum G_n} \quad b = \frac{\sum y_n G_n}{\sum x_n G_n} \quad c = \frac{\sum y_n G_n}{\sum x_n^2 G_n}$$

Using those formulas it is easy to evaluate systematic effects on the track parameters due to systematic errors on the position measurements

Examples:

displacement of vertex detector with respect to the central detector

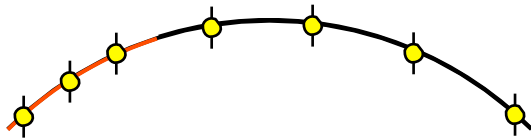

$$y_0 \rightarrow y_0 + \delta \quad y_1 \rightarrow y_1 + \delta \quad y_2 \rightarrow y_2 + \delta$$

Inserting, for example, in the formula for the curvature

$$c = \frac{\sum y_n G_n}{\sum x_n^2 G_n} + \delta \frac{\sum_{n=0}^3 G_n}{\sum x_n^2 G_n} \equiv c_{true} + \delta c$$

a more sophisticated effect could be the rotation of the vertex detector

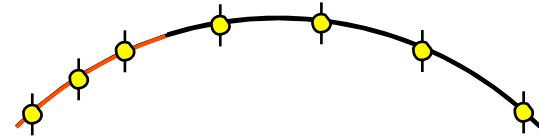

$$y_0 \rightarrow y_0 + \delta_0 \quad y_1 \rightarrow y_1 + \delta_1 \quad y_2 \rightarrow y_2 + \delta_2$$

$$c = \frac{\sum y_n G_n}{\sum x_n^2 G_n} + \frac{\sum_{n=0}^3 \delta_n G_n}{\sum x_n^2 G_n} \equiv c_{true} + \delta c$$

Systematic Effects: Misalignment

Let's assume that one measurement is systematically displaced: misalignment or distortion (systematic error)

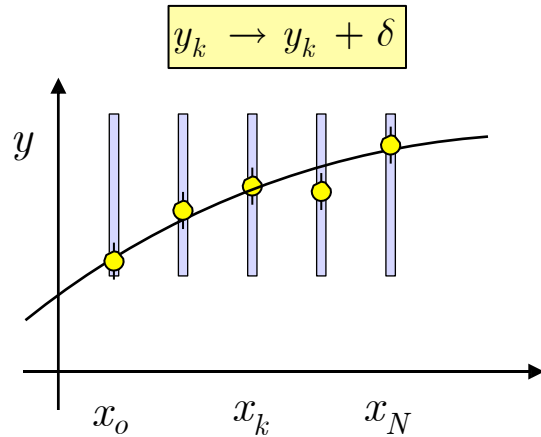

Recall the formula for the radius from the parabola fit

$$\frac{1}{2R} = \frac{\sum y_n G_n}{\sum x_n^2 G_n}$$

introducing the coordinate with error

$$\frac{1}{2R} = \frac{\sum y_n G_n}{\sum x_n^2 G_n} + \frac{G_k}{\sum x_n^2 G_n} \delta$$

$$\frac{1}{2R} = \frac{1}{2R_{true}} + \frac{G_k}{\sum x_n^2 G_n} \delta \quad \boxed{\Delta \frac{1}{R} \sim 2 \frac{\delta}{L^2}}$$

the second term is the systematic effect on the radius due to the systematic error on the measurement

Since the coefficients G_k are known the effect can be precisely estimated

Please notice

the sign of the systematic error on $1/R$ is fixed by the sign of δ

$$Q = +1 \quad \frac{1}{R} > 0$$

$$Q = -1 \quad \frac{1}{R} < 0$$

$\left| \frac{1}{R} \right|$ increases

$\left| \frac{1}{R} \right|$ decreases

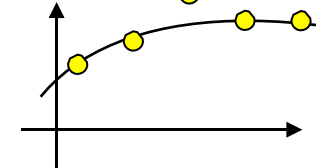
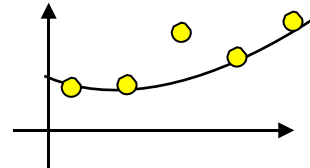

Systematic Effects: Misalignment

As an example consider a systematic effect as seen in the ALEPH TPC

The resolution was studied using muon pairs produced in $e^+ e^-$ annihilation at the Z^0 peak

The muon are produced back to back and have exactly half the c.m. energy each

The plot show the momentum reconstructed separately for positive and negative muons

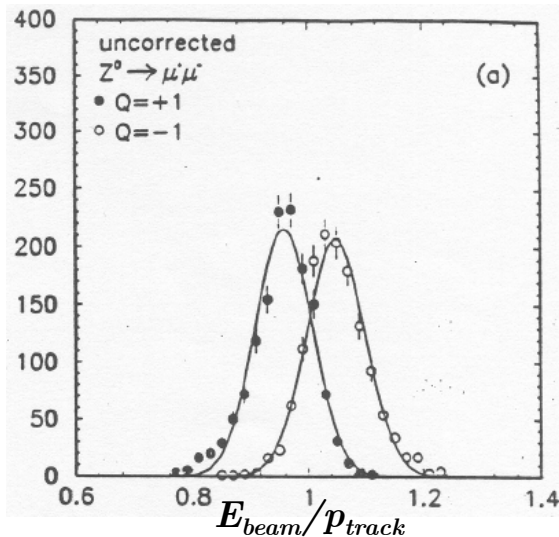

As the plot clearly show the error is quite large

To account for this error $\delta \sim 1 \text{ mm}$!

Magnetic field distortion

A correction procedure is the essential

The following plot shows the same distribution after proper magnetic distortion corrections are applied

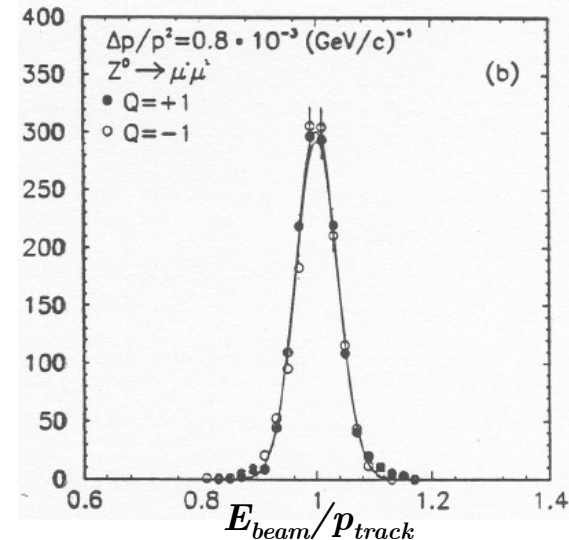

Problems With The Fit Procedure

We have learned how to use linear models to fit the projection of the charged particle track

The method could be extended to non linear problems (inhomogeneous magnetic field) by linearization and iteration

The solution of the problem is given by

$$\mathbf{p} = (\mathbf{A}^T \mathbf{W} \mathbf{A})^{-1} \mathbf{A}^T \mathbf{W} \mathbf{Y} \quad \mathbf{W} = \mathbf{V}^{-1}$$

to solve the problem the matrix \mathbf{V} has to be inverted

easy if \mathbf{V} diagonal (time $O(n)$)

We have seen that multiple scattering introduces correlation among measurements and makes \mathbf{V} non diagonal

For large detectors the dimension of \mathbf{V} can be prohibitively large (time $O(n^3)$)

The fit is normally used to rank track candidates during pattern recognition

The fit procedure gives the track parameters at a given surface or plane

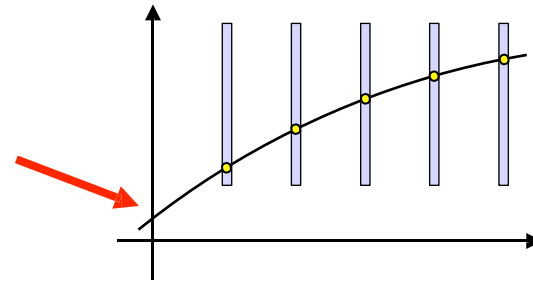

Often prediction of the track crossing point at a different plane is needed

impact parameter match

with calorimeters

match with particle ID (RICH)

The fit procedure described is not optimal for this problem:

multiple scattering makes prediction (extrapolation) non optimal

Kalman Filter

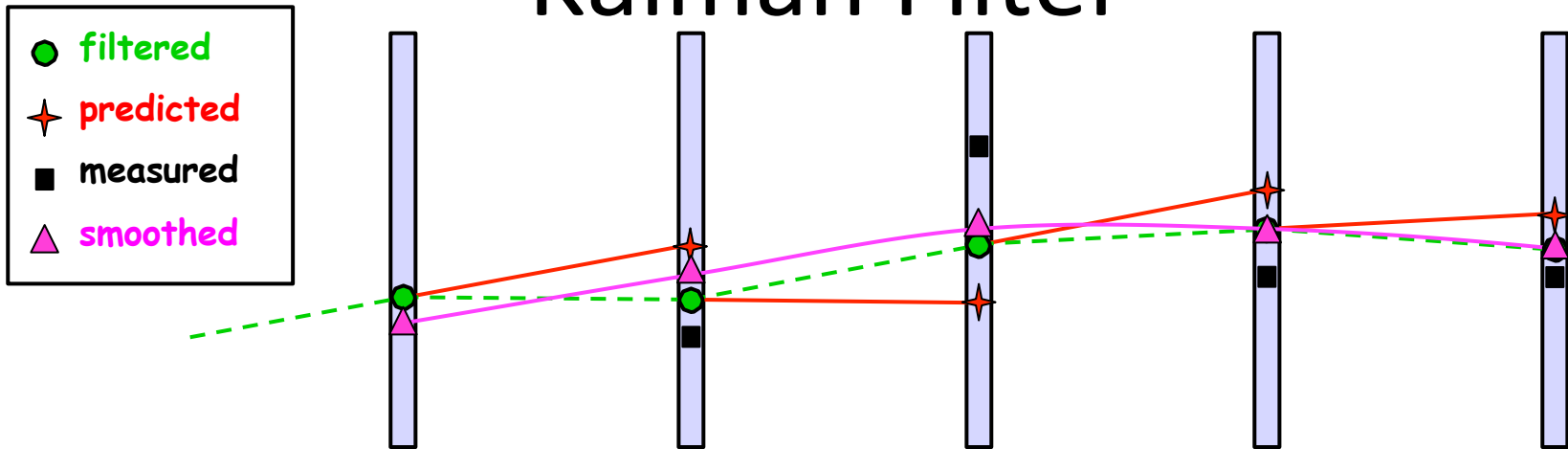

to start the Kalman Filter we need a seed
 the position on the next plane is **predicted**
 the measurement is considered

prediction and measurement are merged
 (**filtered**)

then new **prediction** ... measurement ...

filtering ... **prediction** ... measurement ...

filtering ... **prediction** ... measurement ...

The filtered trajectory

The smoothed trajectory

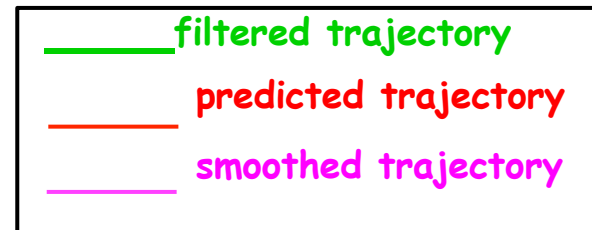

Kalman Filter

The filtering is nothing but a weighted average of the

new measurement y_n

the prediction y_p

$$y_f = \frac{\frac{1}{\sigma_p^2} y_p + \frac{1}{\sigma_n^2} y_n}{\frac{1}{\sigma_p^2} + \frac{1}{\sigma_n^2}}$$

$$y_f = \frac{\sigma_n^2}{\sigma_p^2 + \sigma_n^2} y_p + \frac{\sigma_p^2}{\sigma_p^2 + \sigma_n^2} y_n$$

Clearly if the new measurement has a very large error

$$\sigma_n \rightarrow \infty \quad y_f \rightarrow y_p$$

measurement ignored

If the prediction has a large error (for example large multiple scattering)

$$\sigma_p \rightarrow \infty \quad y_f \rightarrow y_n$$

prediction ignored

The effect of multiple scattering, or any other stochastic effect, can be handled in the prediction

The advantages of this procedure are

is an iterative procedure

not necessary to invert large matrices

is a local procedure: at any step the estimate at the given plane is the best that make use of the previous measurements

Kalman Filter

The consequence is that if you want the optimal measurement at the origin you have to start the filter from the end of the track

After all the measurements have been used (filtered) it is possible to build a procedure that

uses the (stored) intermediate results of the filter

gives the best parameter estimation at any point

This is the smoother

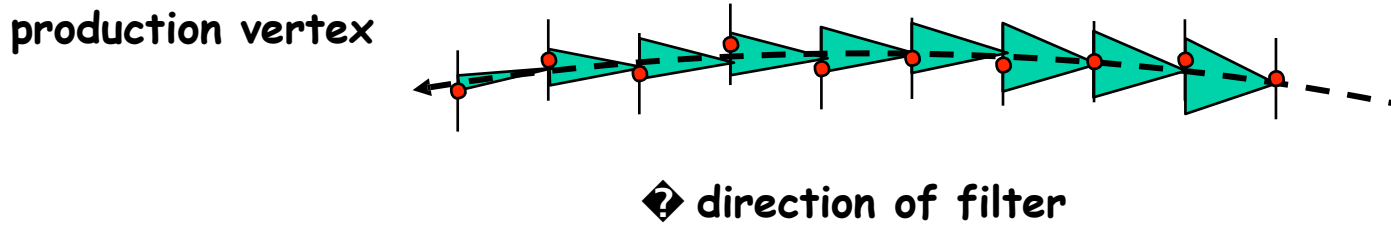
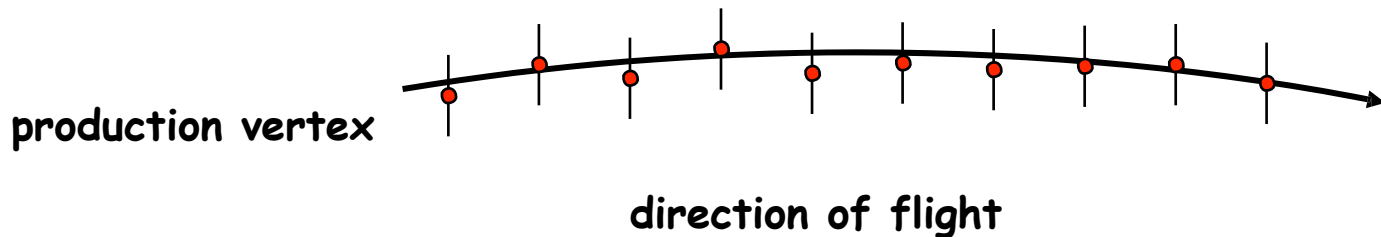

Kalman Filter

Applications of Kalman Filter:

- navigation
- radar tracking
- sonar ranging
- satellite orbit computation
- stock prize prediction

It is used in all sort of fields

- Eagle landed on the moon using KF
- Gyroscopes in airplanes use KF

Usually the problem is to estimate a state of some sort and its uncertainty

- location and velocity of airplane
- track parameters of charged particles in HEP experiments

However we do not observe the state directly

We only observe some measurements from sensors which are noisy:

- radar tracking
- charged particle tracking detectors

As an additional complication the state evolve in time with is own uncertainties: process stochastic noise

- deviation from trajectory due to random wind
- multiple scattering

In case of tracking in HEP instead of time we can consider the evolution of the track parameter at the discrete layers where the detectors perform the measurement

Kalman Filter

We give here the basics equations of the Kalman Filter

Detailed discussion can be found in [2: Bock et al 1990], [6: Avery 1992], [7: Frühwirth 1987], [8: Billoir 1985]

Consider 2 planes of our system

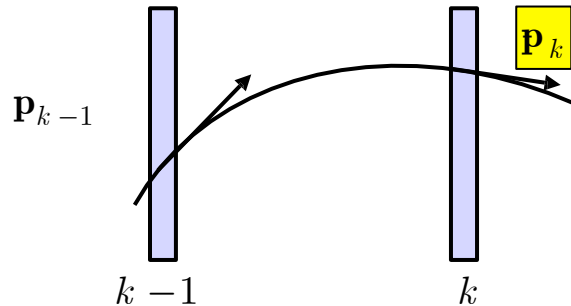

The measurements up to plane $k - 1$ allowed us to get an estimate of the track parameters \mathbf{p}_{k-1}

We then propagate \mathbf{p}_{k-1} to plane k

$$\mathbf{p}_k = \mathbf{F}_k \mathbf{p}_{k-1} \quad \mathbf{F}_k = \frac{\partial \mathbf{f}_k}{\partial \mathbf{p}_{k-1}}$$

The covariance matrix of \mathbf{p}_{k-1} is \mathbf{C}_{k-1}

The covariance matrix \mathbf{C}_k of \mathbf{p}_k is

$$\mathbf{C}_k = \mathbf{F}_k \mathbf{C}_{k-1} \mathbf{F}_k^T + \mathbf{M}_{ms}$$

The matrix \mathbf{M}_{ms} accounts for the effect of multiple scattering on the parameters covariance matrix

On plane k we have some measurements \mathbf{m}_k with a covariance matrix \mathbf{V}

Using the track model (k means: origin at plane k !)

$$\mathbf{y}_k = \mathbf{H}_k \mathbf{p}_k$$

we can obtain a second estimate of the track parameter at plane k : \mathbf{q}_k

$$\chi^2 = (\mathbf{y}_k - \mathbf{m}_k)^T \mathbf{V}^{-1} (\mathbf{y}_k - \mathbf{m}_k)$$

$$\chi^2 = (\mathbf{H}_k \mathbf{p}_k - \mathbf{m}_k)^T \mathbf{V}^{-1} (\mathbf{H}_k \mathbf{p}_k - \mathbf{m}_k)$$

minimizing χ^2 gives the second estimate \mathbf{q}_k

Kalman Filter

Summarising we have

the estimate propagated

$$\mathbf{p}_k$$

with its covariance matrix

The second estimate from the measurement at plane k

$$\mathbf{q}_k$$

with its covariance matrix

We can obtain a proper weighted average of those 2 estimate

This is the filtered value at plane k

Details and formulas can be found in the cited references

The advantage of this method are

it is clearly iterative

at each step the problem has low dimensionality and no large matrix has to be inverted

the computation time increases only linearly with the number of detectors

The estimated track parameters closely follows the real path of the particle

the linear approximation of the track does not need to be valid over the whole track length but only from one detector to the next

References

- 1 Gluckstern R.L.
Uncertainties in track momentum and direction, due to multiple scattering and measurement errors
NIM 24 p. 381 (1963)
- 2 Bock R. K., Grote H., Notz D., Regler M. Data Analysis technique for high energy physics experiments
Cambridge University Press 1990
- 3 Blum W., Rolandi L.
Particle detection with drift chambers
Springer-Verlag 1993
- 4 Avery P.
Applied fitting teory I: General Least Squares Theory
Cleo note CBX 91-72 (1991)
see: <http://www.phys.ufl.edu/~avery/fitting.html>
- 5 Avery P.
Applied fitting teory III: Non Optimal Least Squares Fitting and Multiple Scattering
Cleo note CBX 91-74 (1991)
see: <http://www.phys.ufl.edu/~avery/fitting.html>
- 6 Avery P.
Applied fitting teory V: Track Fitting Using the Kalman Filter
Cleo note CBX 92-39 (1992)
see: <http://www.phys.ufl.edu/~avery/fitting.html>
- 7 Frühwirth R.
Application of Kalman Filtering to Track and Vertex Fitting
NIM A262 p. 444 (1987)
- 8 Billoir P.
Track Element Merging Strategy and Vertex Fitting in Complex Modular Detectors
NIM A241 p. 115 (1985)

thank you for reading this lecture note:
I hope you found it useful.

If you find errors I will be grateful if
you send me an email at
francesco.ragusa@mi.infn.it