

Electroweak Physics at D0: Stories the W can tell...

Andrew Askew
Rutgers University

I will show:

- Recent results featuring the W boson at D0:
 - The W Charge Asymmetry: Probing the structure of the proton.
 - $W\gamma$: bringing the W to light (or vice versa).
- But before we jump into these two topics...let's get a running start.

The Questions that drive us...

- For thousands of years, we've been asking the questions:
 - What is matter made of?
 - How does it work?

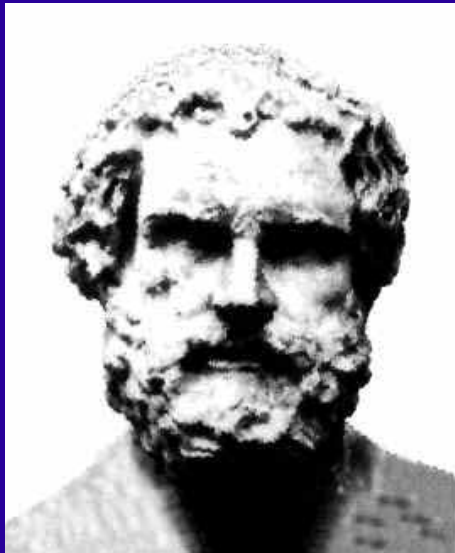

- Democritus of Abdera
~ 460BC – 370 BC

“There exists Void and Being.
Being is made of atoms”

The Questions that drive us...

- For thousands of years, we've been asking the questions:
 - What is matter made of?
 - How does it work?

- Democritus of Adbera
~ 460BC – 370 BC

“There exists Void and Being.
Being is made of atoms”

Time passes, things get more complicated.

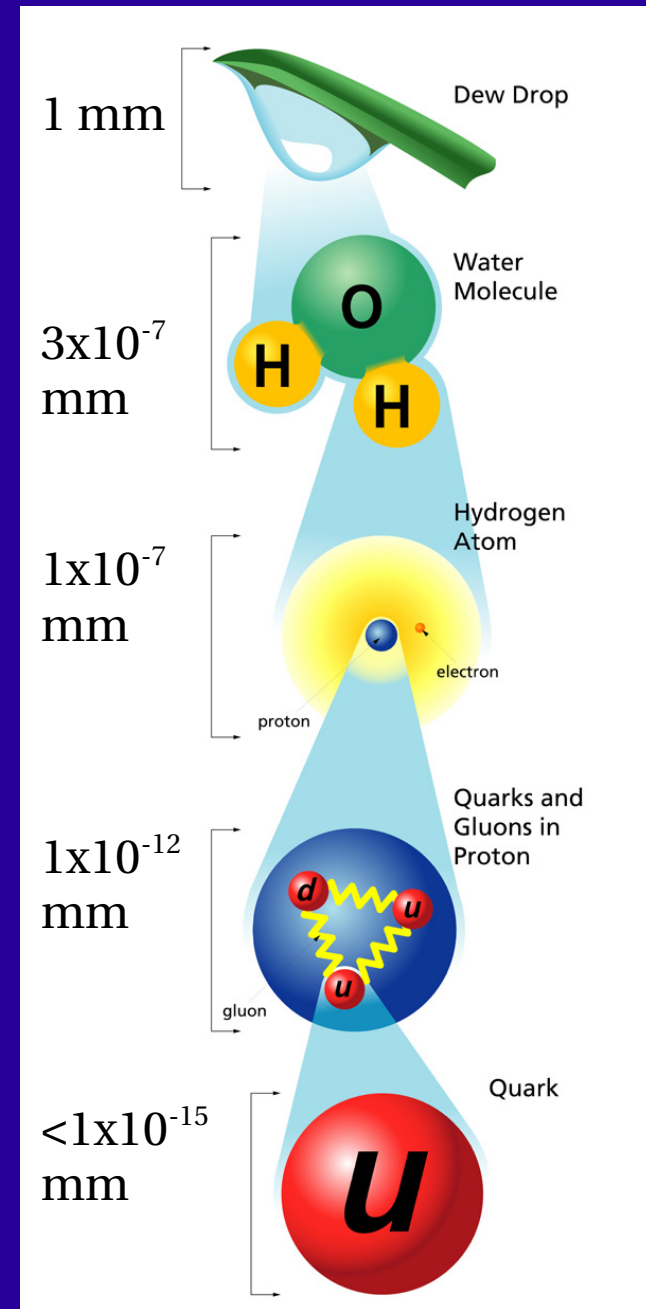
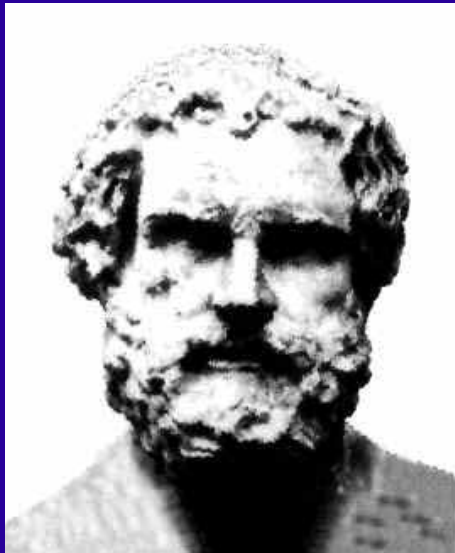

The Questions that drive us...

- For thousands of years, we've been asking the questions:
 - What is matter made of?
 - How does it work?

To get down to this length scale requires a lot of energy:

$$\ell = \frac{\hbar c}{p} \quad \text{De Broglie wavelength}$$

$$p = \frac{\hbar c}{\ell} = \frac{(6.5 \times 10^{-16} \text{ eVs}) \times (3 \times 10^{11} \text{ mm/s})}{10^{-15} \text{ mm}} \approx 200 \text{ GeV}$$

What do we see when we have access to this length scale? What are our new 'atoms'?

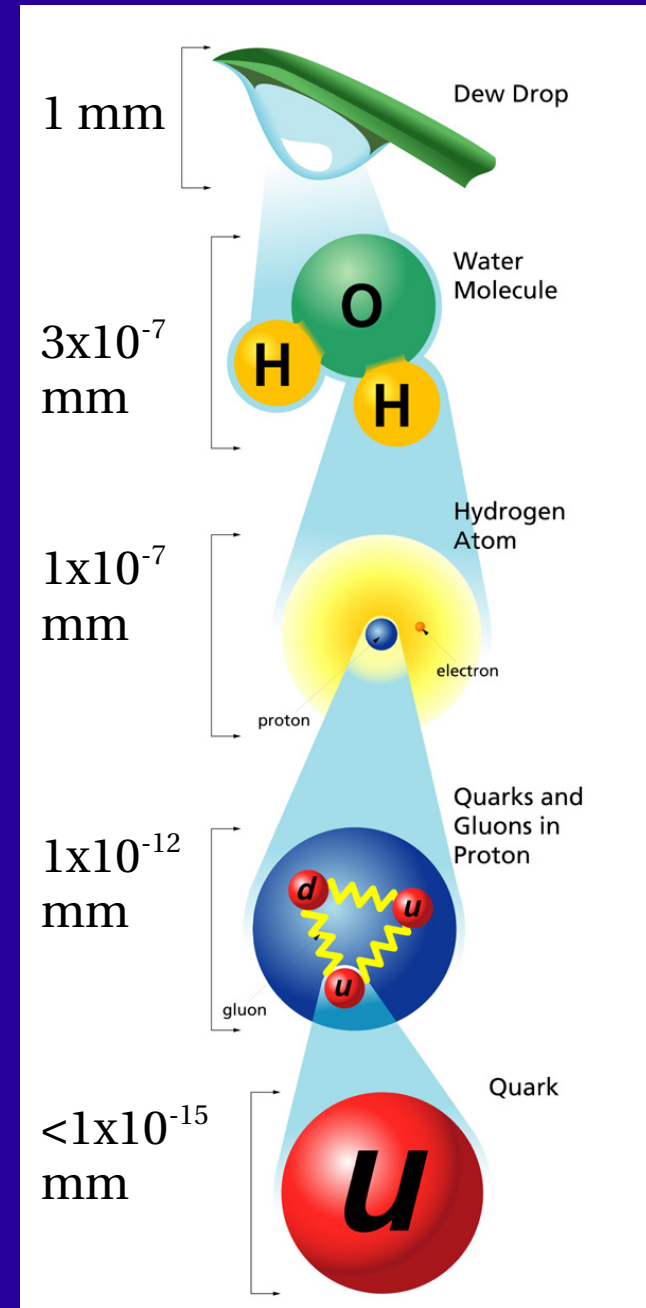

Our new 'atoms'

- So upon closer examination, we have a different set of atoms.

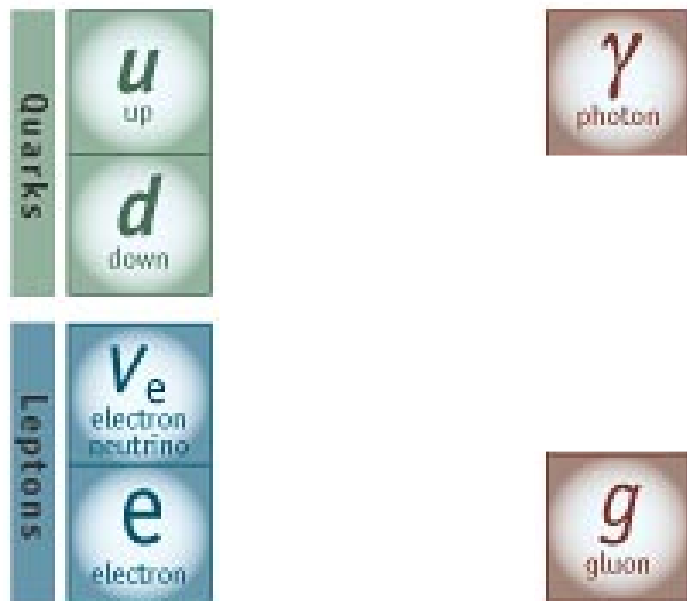

Our new 'atoms'

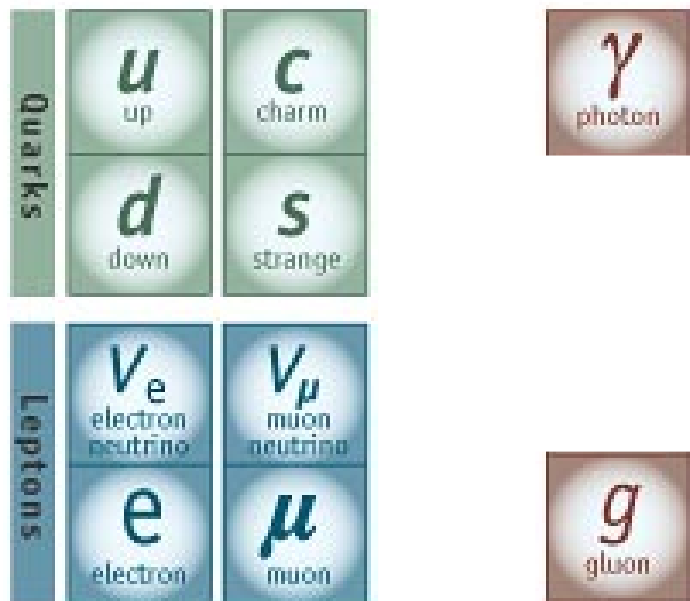

- So upon closer examination, we have a different set of atoms.
- And if we look more closely, we reveal more.

Our new 'atoms'

Quarks	u up	c charm	t top	γ photon
	d down	s strange	b bottom	Z Z boson
Leptons	ν_e electron neutrino	ν_μ muon neutrino	ν_τ tau neutrino	W W boson
	e electron	μ muon	τ tau	g gluon

- So upon closer examination, we have a different set of atoms.
- And if we look more closely, we reveal more.
- And still more.

Thus far...

- The Standard Model: An enormous success.

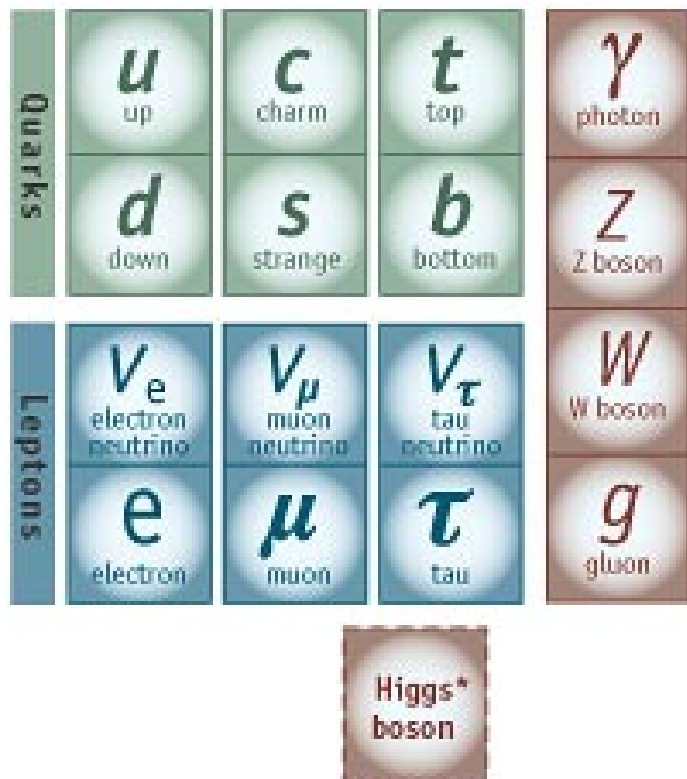

- Provides an understanding of what nucleons, atoms, stars, you and me are made of.
- Describes how all of matter's constituents interact with one other.

Thus far...

- The Standard Model: Unanswered questions...

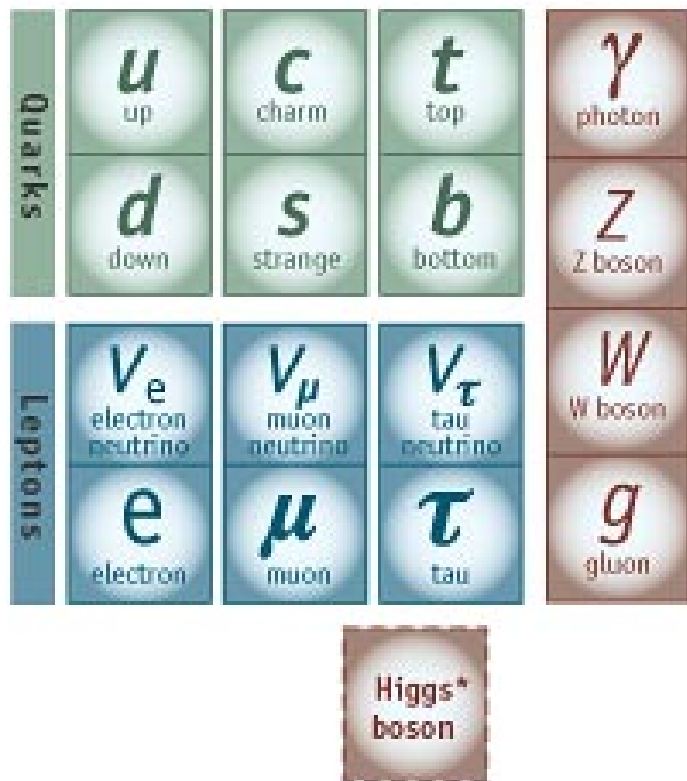

- Matter-Antimatter asymmetry in the universe (why is there so much stuff around?).
- Dark matter/energy (what is this other stuff?).
- Particle masses (why is some stuff light, and other stuff...not?).
- Democritus had 4 atoms. We have at least 16.

About that Higgs...

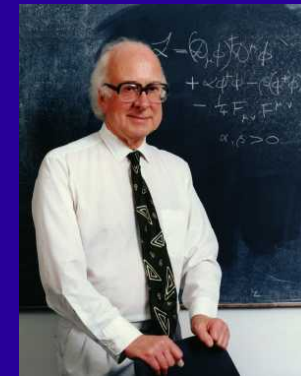
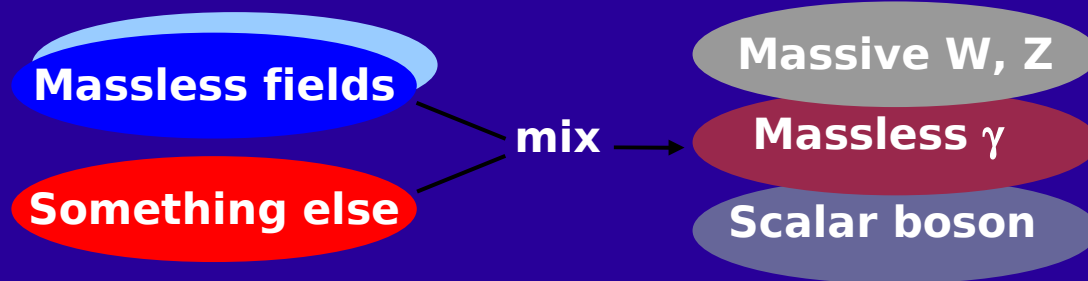

The "Higgs Mechanism"

- The Higgs is the last "piece" of the Standard Model, but it doesn't really **explain** anything.
 - It's really an ad-hoc mechanism to give masses to the W and Z bosons, while leaving the photon massless.
- Once you accept that there IS a Higgs, then the strength with which the W, Z and γ interact with each other is fixed.
- If there is no Higgs however, then these are NOT fixed. Testing these interactions then becomes very important.
- How do we test them?

About that Higgs...

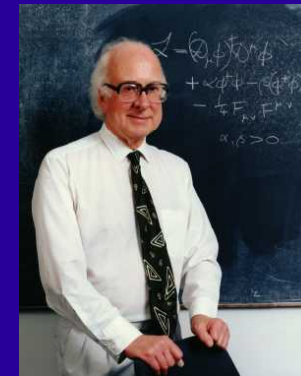
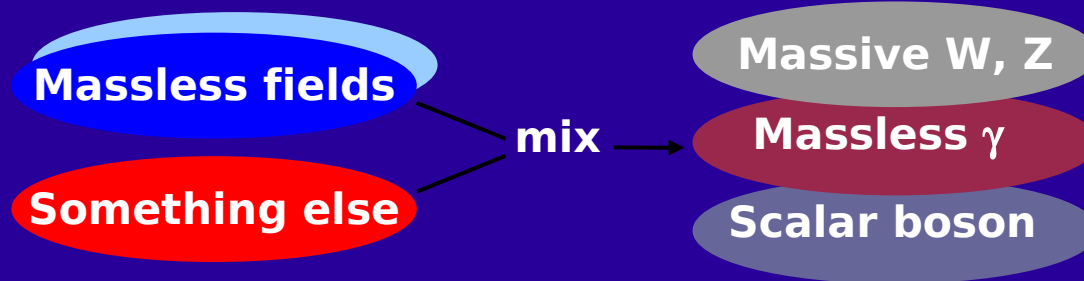

The “Higgs Mechanism”

- The Higgs is the last “piece” of the Standard Model, but it doesn't really **explain** anything.
 - It's really an ad-hoc mechanism to give masses to the W and Z bosons, while leaving the photon massless.
- Once you accept that there IS a mechanism with which the W, Z and γ interact...
- If there is no Higgs however, then... Testing these interactions then...
- How do we test them?

Nobel prize in physics in 2008 awarded in part to Yoichiro Nambu for:
 “the discovery of the mechanism for spontaneously broken symmetry in subatomic physics.”

Get a collider/microscope: the Tevatron

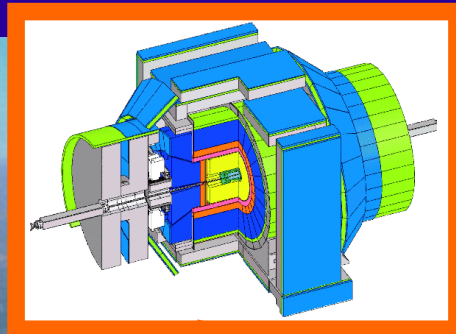
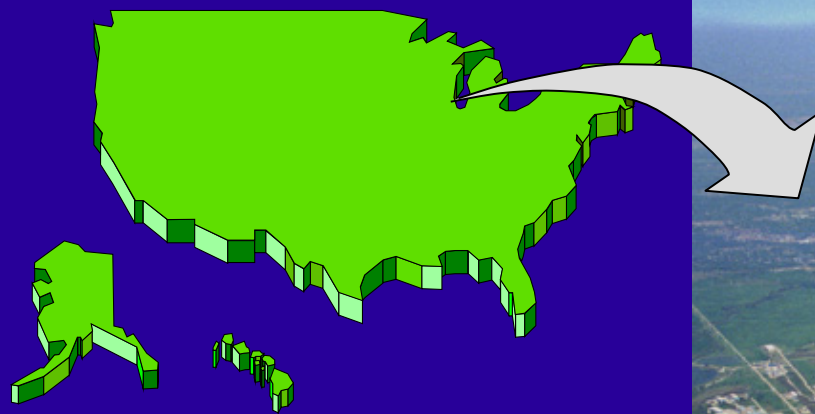

Chicago

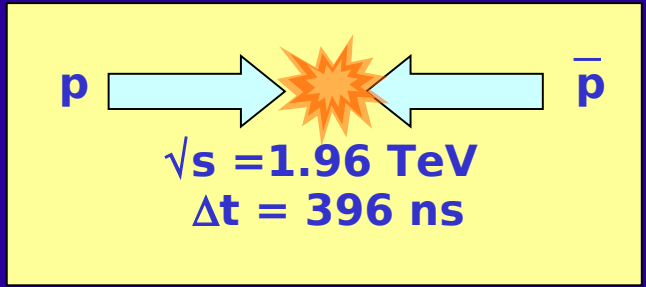
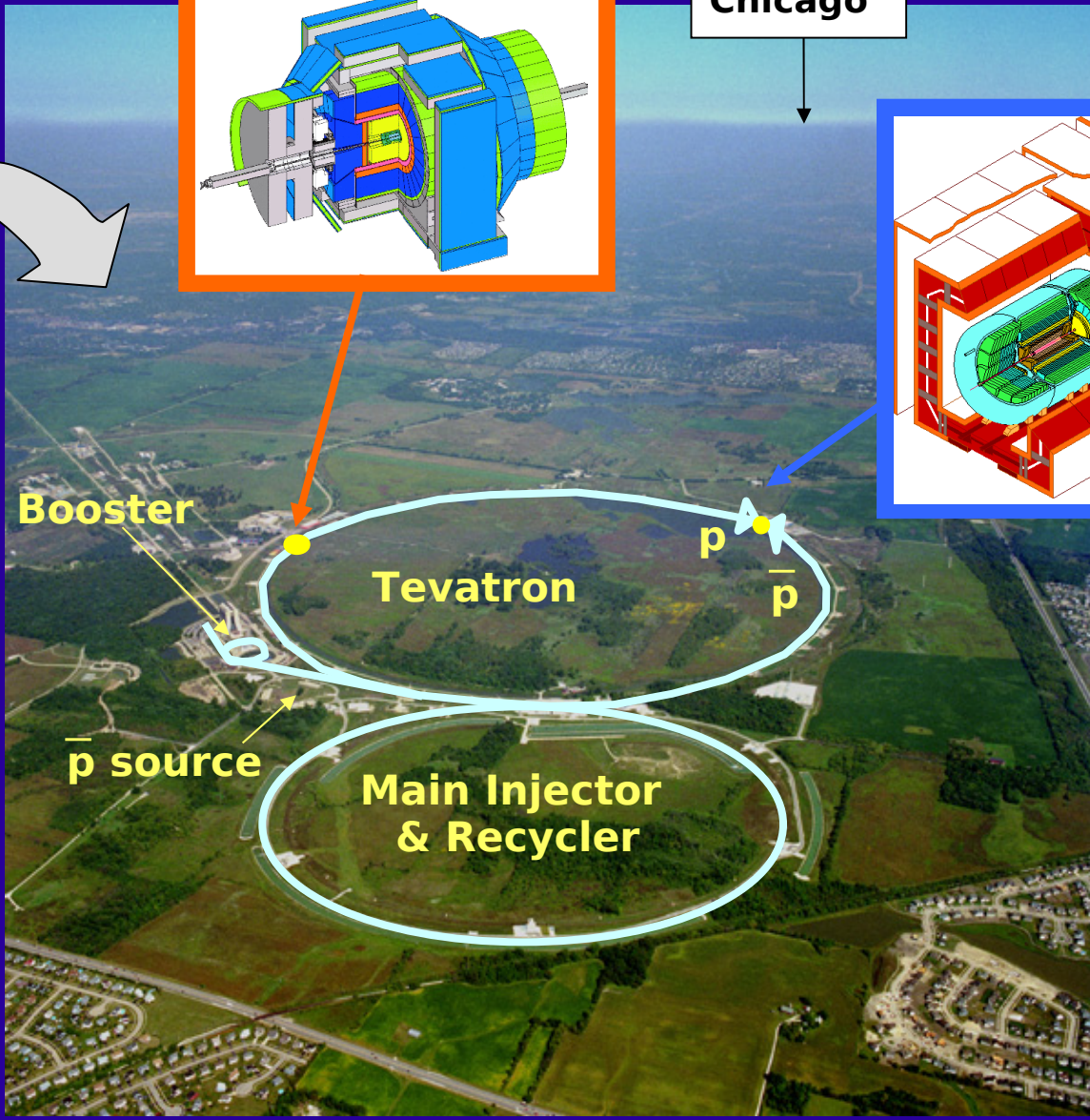
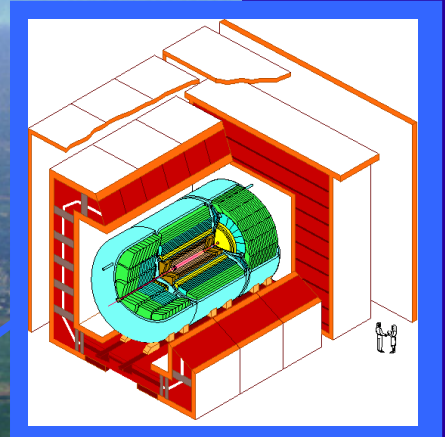

Run I 1992-96
Run II 2001-09

To probe high energy (small distance), we collide beams of particles.

The LHC: A bigger microscope

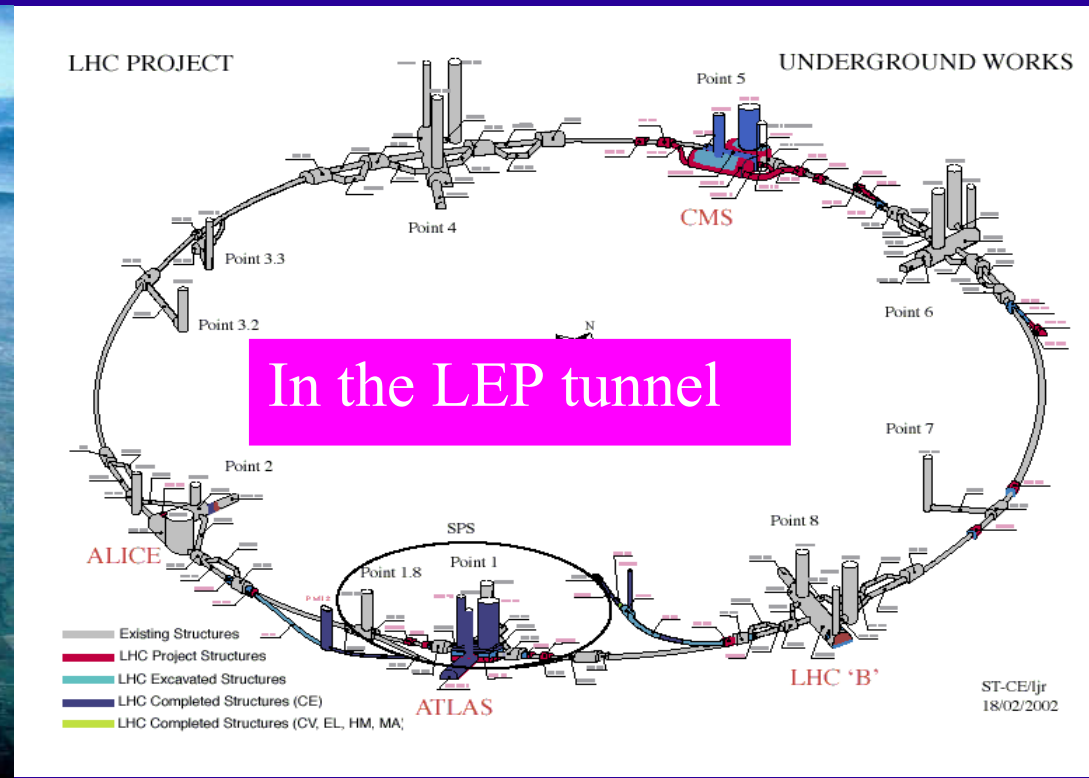

- ★ $pp \sqrt{s} = 14 \text{ TeV}$
- ★ crossing rate 40 MHz (25 ns)
- ★ circumference of 27 km (16.8 miles)

Get a collider/microscope: the Tevatron

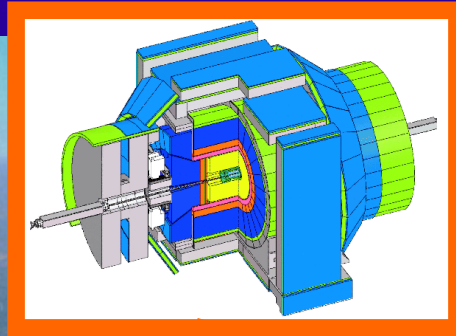
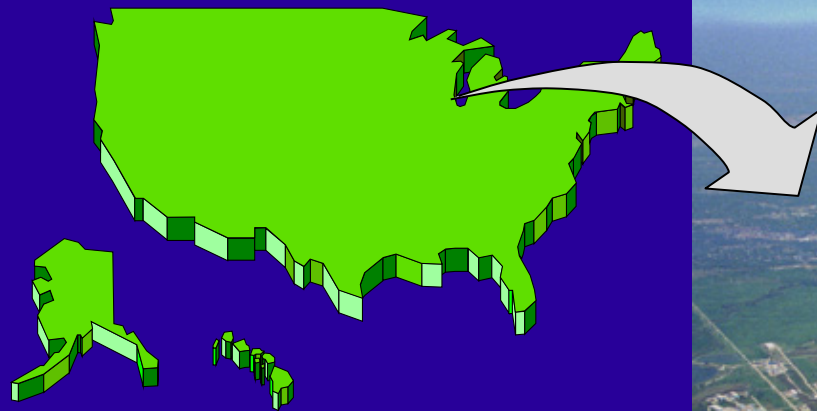

Chicago

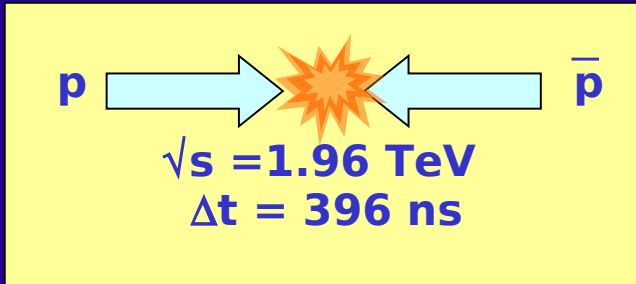
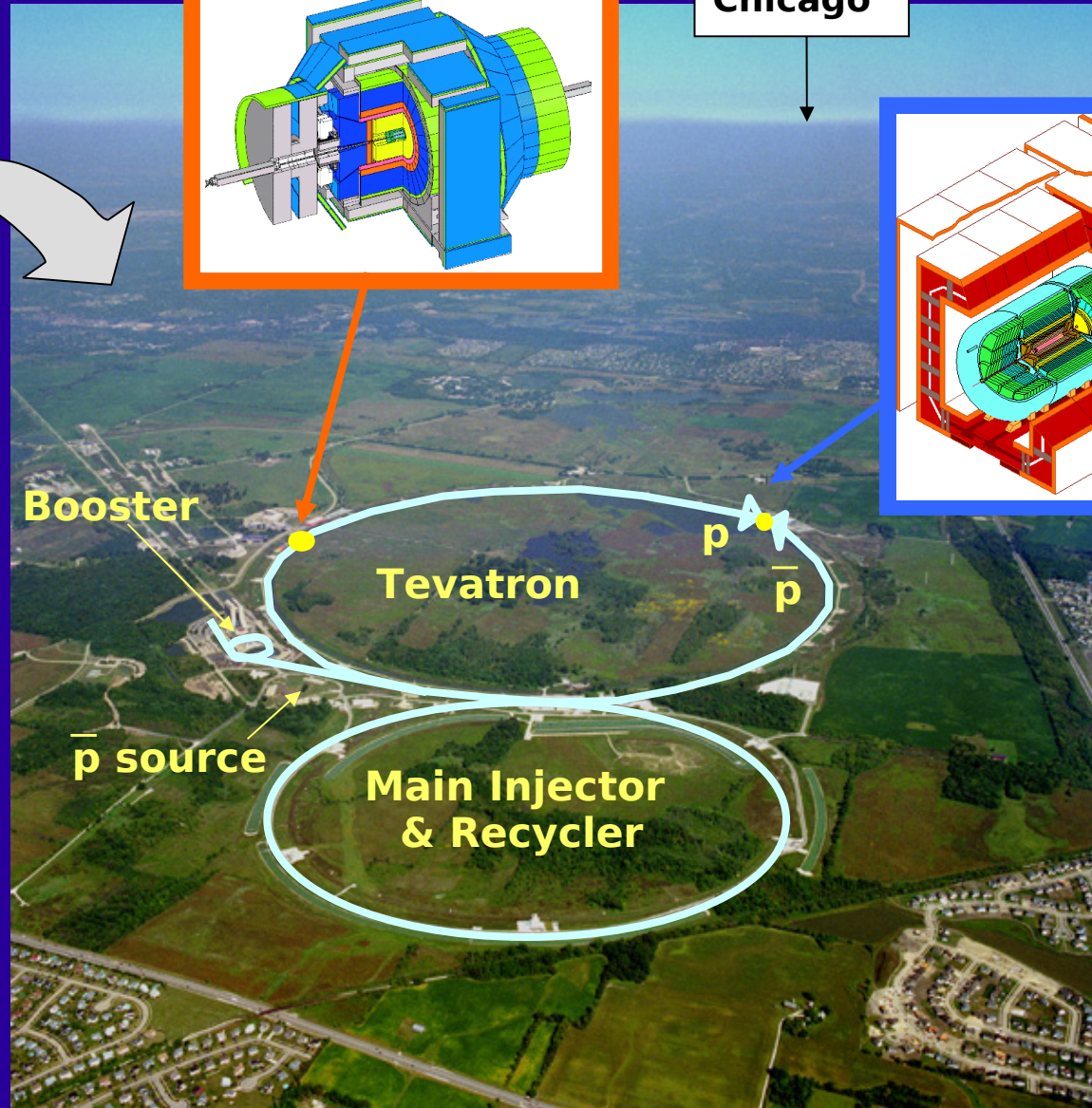
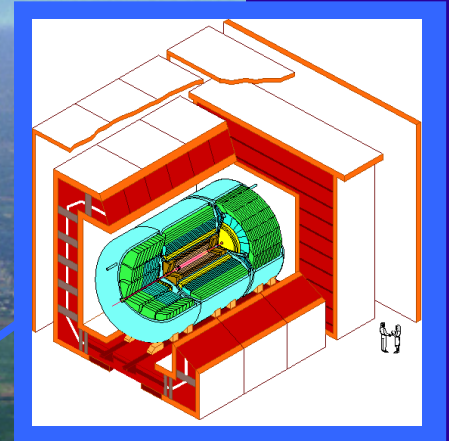

Run I 1992-96
Run II 2001-09

To probe high energy (small distance), we collide beams of particles.

The D0 Detector:

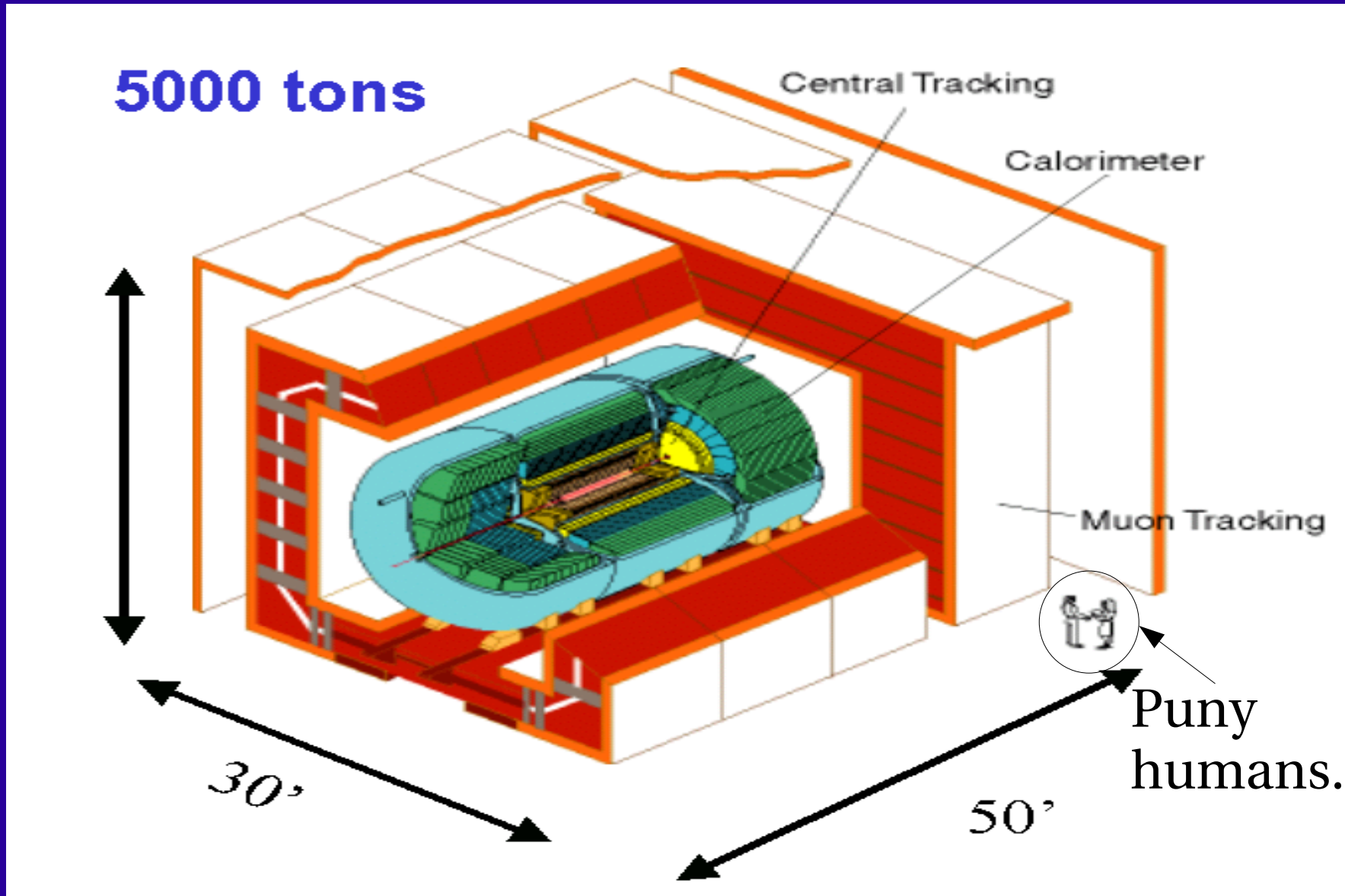

The D0 Experiment:



Serving as a reminder that it's the human brains that use the apparatus that actually make this an experiment.

Proton-Antiproton Collisions:

- A messy business: these aren't point particles, protons and antiprotons are made up of quarks and gluons.

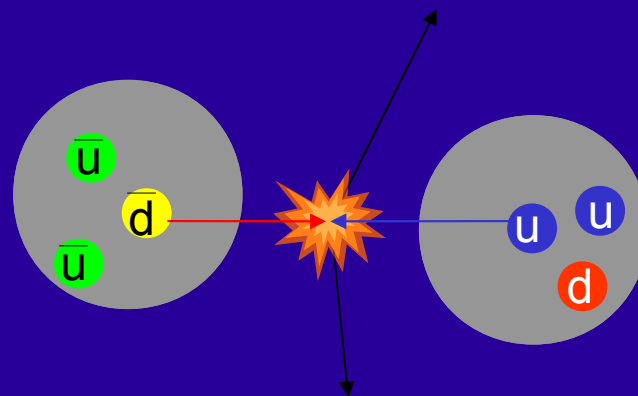

Proton-Antiproton Collisions:

- A messy business: these aren't point particles, protons and antiprotons are made up of quarks and gluons.

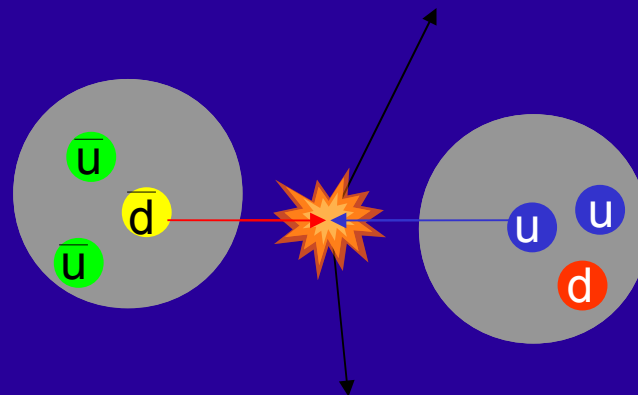

- How messy? Imagine a balloon in which one places three billiard balls.

Proton-Antiproton Collisions:

- A messy business: these aren't point particles, protons and antiprotons are made up of quarks and gluons.

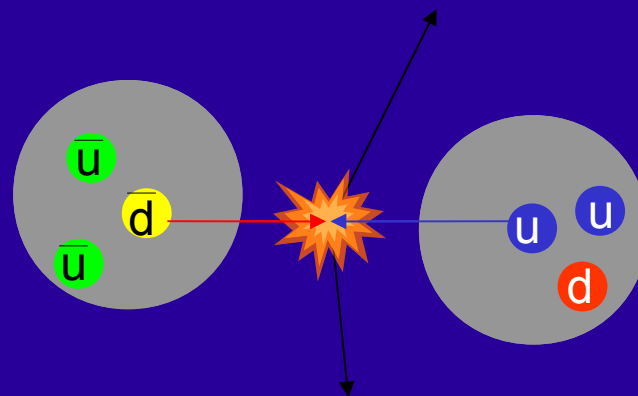

- How messy? Imagine a balloon in which one places three billiard balls. Then fill the remaining space with Jello.

Proton-Antiproton Collisions:

- A messy business: these aren't point particles, protons and antiprotons are made up of quarks and gluons.

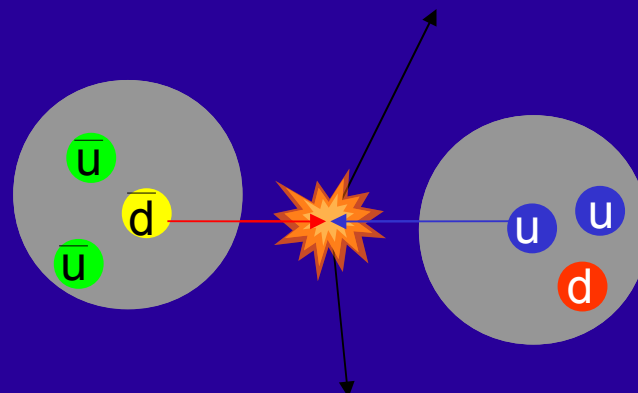

- How messy? Imagine a balloon in which one places three billiard balls. Then fill the remaining space with Jello. Now make a second one of these.

Proton-Antiproton Collisions:

- A messy business: these aren't point particles, protons and antiprotons are made up of quarks and gluons.

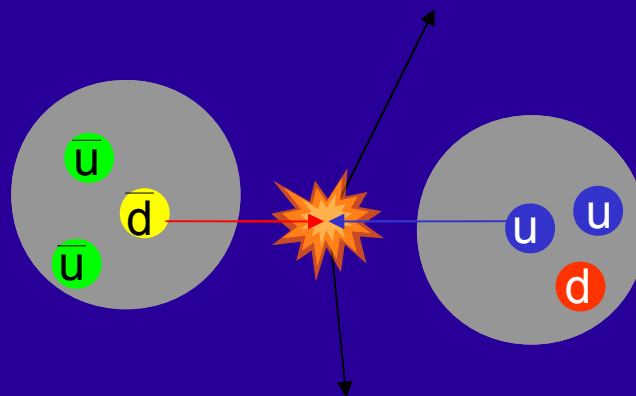

- How messy? Imagine a balloon in which one places three billiard balls. Then fill the remaining space with Jello. Now make a second one of these.
- Now smash them together as hard as you can. Messy.

Proton-Antiproton Collisions:

- A messy business: these aren't point particles, protons and antiprotons are made up of quarks and gluons.

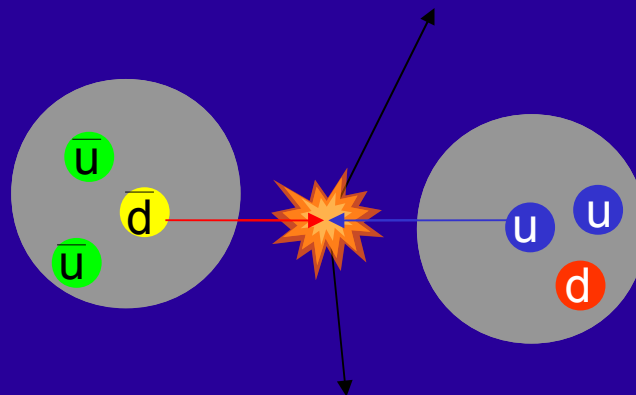

- How messy? Imagine a balloon in which one places three billiard balls. Then fill the remaining space with Jello. Now make a second one of these.
- Now smash them together as hard as you can. Messy.
- Go ahead, try it at home!

Proton-Antiproton Collisions:

- A messy business: these aren't point particles, protons and antiprotons are made up of quarks and gluons.

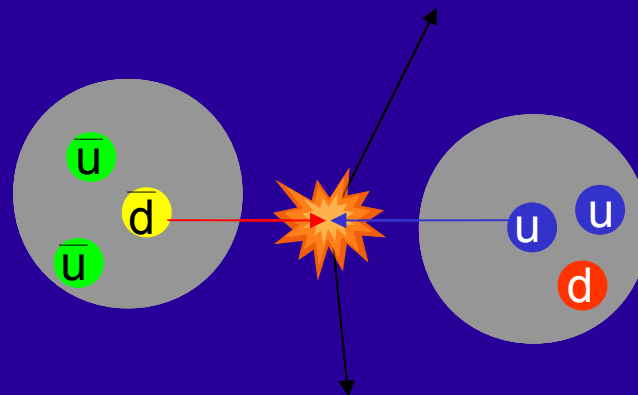

- How messy? Imagine a balloon in which one places three billiard balls. Then fill the remaining space with Jello. Now make a second one of these.
- Now smash them together as hard as you can. Messy.
- Go ahead, try it at home!
- The point of all of this is: We're colliding composite particles in an attempt to recreate how the universe acts at high energy scales. This is not clear cut, or simple.

Composite particles:

- I've mentioned already that protons are made up of quarks and gluons.
 - In fact, a proton isn't just composed of three quarks, the Jell-o from the example is a 'sea' of gluons and virtual quark-antiquark pairs.

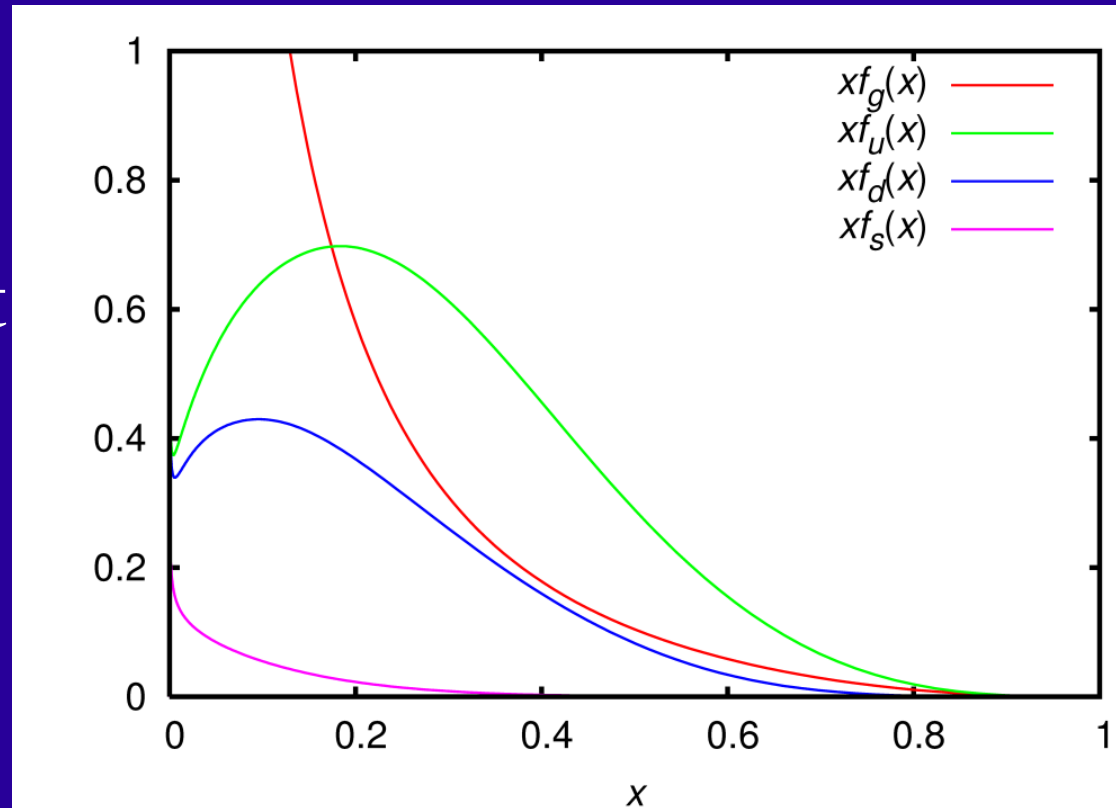
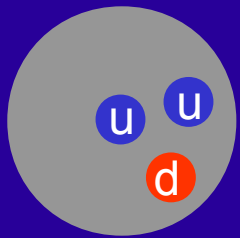

It's vital at hadron colliders to know these distributions! How else do you predict what theory would give you?

W as a probe...

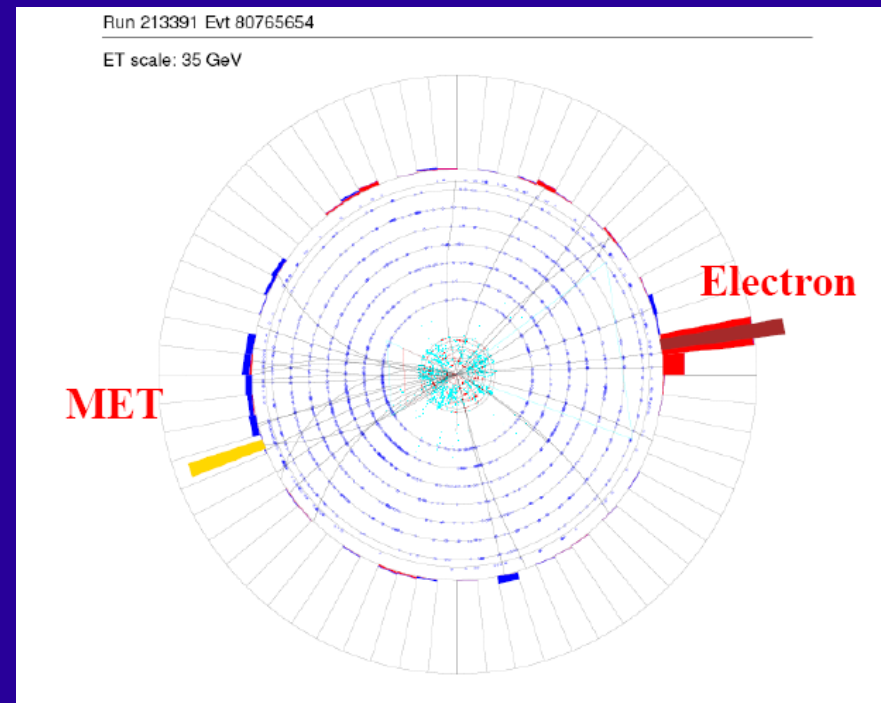
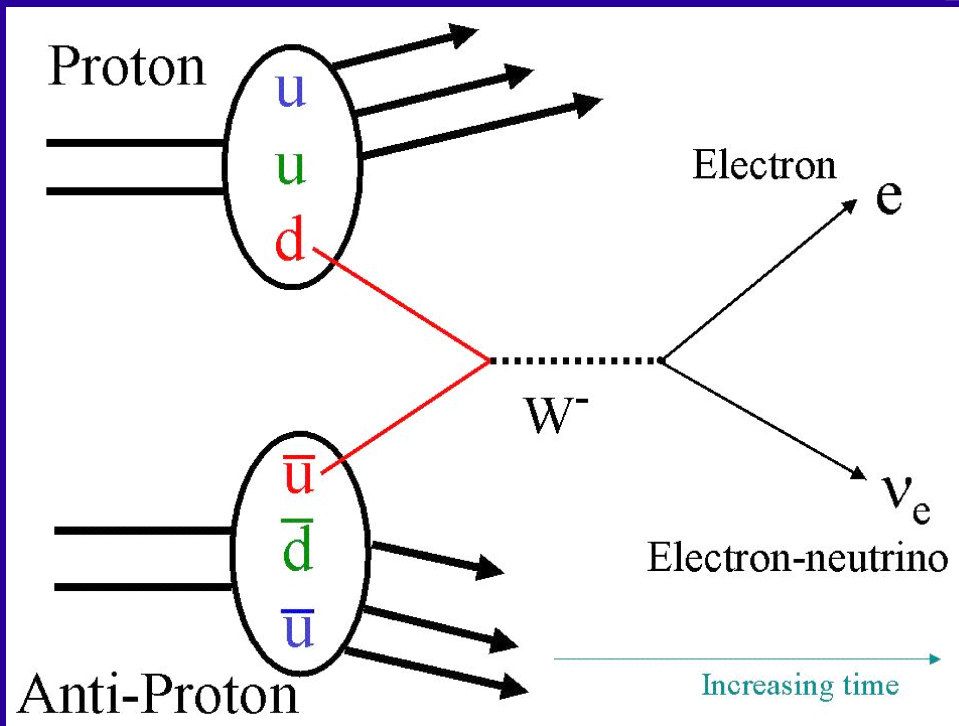

- We can produce W bosons when we collide protons and anti-protons.
- Collect up enough of these events can tell us about the initial quarks that produced them, and their momentum distribution within the proton.

The W Charge Asymmetry:

- It's known that the u-quarks tend to carry more of the proton's momentum than the d-quark.
- Thus the W^+ tends to go in the proton direction, or positive rapidity. Therefore the opposite for the W^- .
- Experimentally, we can access the asymmetry in the production:

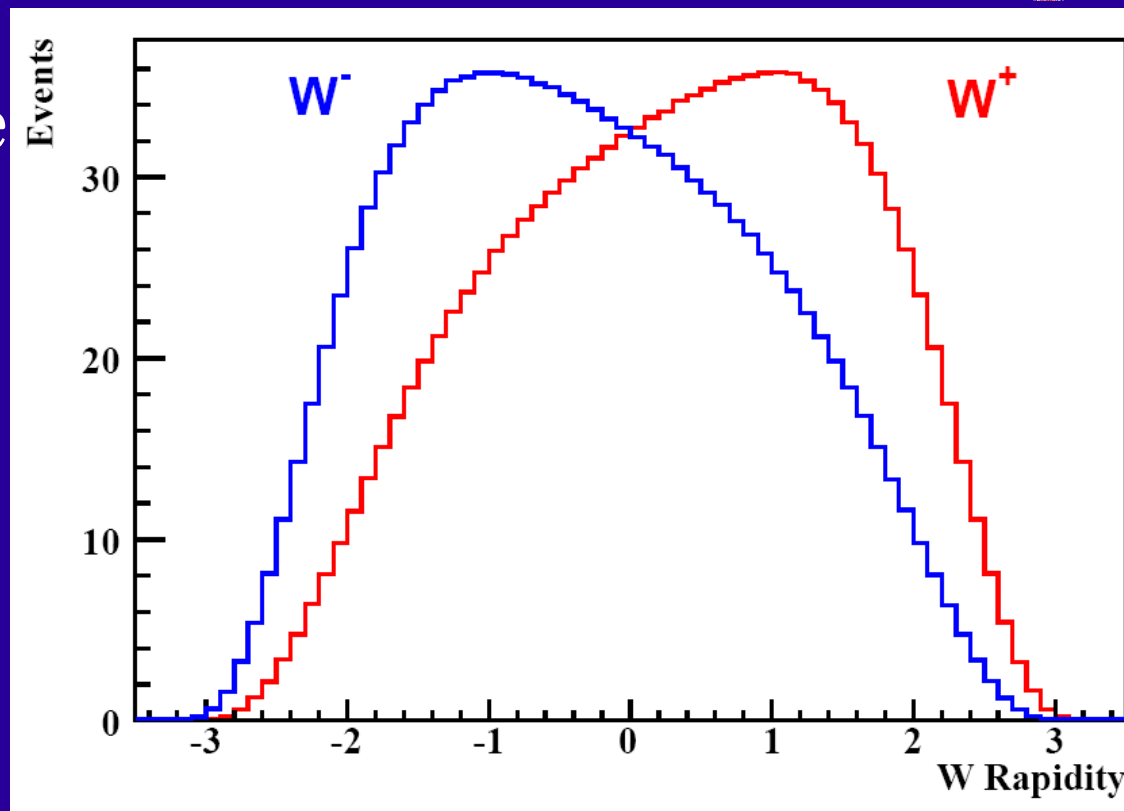

$$y = \frac{1}{2} \ln \frac{E + p_z}{E - p_z}$$

$$A(y) = \frac{d\sigma(W^+) / dy - d\sigma(W^-) / dy}{d\sigma(W^+) / dy + d\sigma(W^-) / dy}$$

To get a bit more technical:

W^+ DECAY MODES	Fraction (Γ_i/Γ)
$e^+ \nu$	$(10.75 \pm 0.13) \%$
$\mu^+ \nu$	$(10.57 \pm 0.15) \%$
$\tau^+ \nu$	$(11.25 \pm 0.20) \%$
hadrons	$(67.60 \pm 0.27) \%$

W^\pm

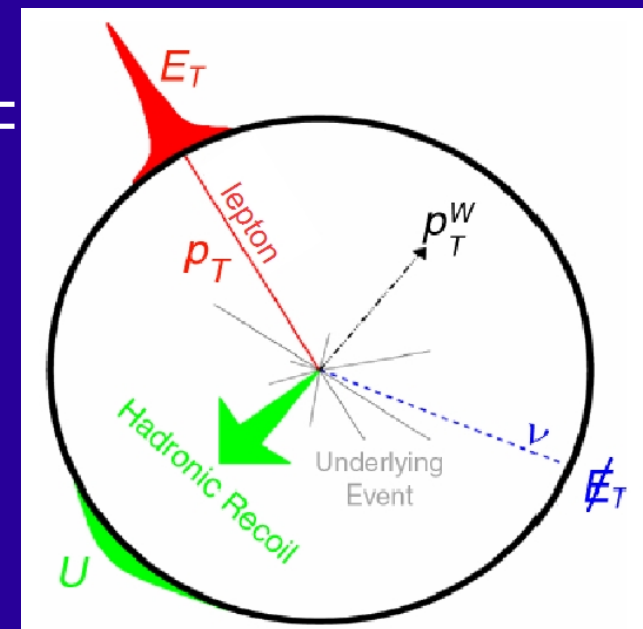

- Yes, there are a lot of hadron decays. These are effectively lost at hadron colliders, unless there's something else around (like in top events).
- We'll look for $W \rightarrow e\nu$, which gives us two additional complications:
 - The escape of the neutrino.
 - Measuring the charge of the electron.

The escape of the neutrino:

- Information is lost about the neutrino (p_z^ν).
- We infer the neutrino p_T from the imbalance of the other energy in the event (mainly the electron). But now we don't know the W rapidity.
- Instead of measuring the W asymmetry then, we measure the electron asymmetry. This is straightforward experimentally.
- It does require we understand the W decay to leptons, to properly account for the correlation.

$$A(y) = \frac{d\sigma(W^+)/dy - d\sigma(W^-)/dy}{d\sigma(W^+)/dy + d\sigma(W^-)/dy}$$



$$A(\eta_l) = \frac{d\sigma(l^+)/d\eta - d\sigma(l^-)/d\eta}{d\sigma(l^+)/d\eta + d\sigma(l^-)/d\eta}$$

$$y = \frac{1}{2} \ln \frac{E + p_z}{E - p_z}$$

$$\eta = -\ln\left(\tan\left(\frac{\theta}{2}\right)\right)$$

Charge Measurement:

- Charge measurement is performed in the magnetic tracking chamber of the experiment.
- It's simple (in theory): You have a charged particle moving in a magnetic field (along the z-axis, B_z). Meaning that the particle curves in the transverse plane.
- Measure the sign of the curvature, and you know the charge.
 - Measure the curvature itself, and you measure the transverse momentum (p_T).
- First a few words about the D0 tracker...

D0 Tracking

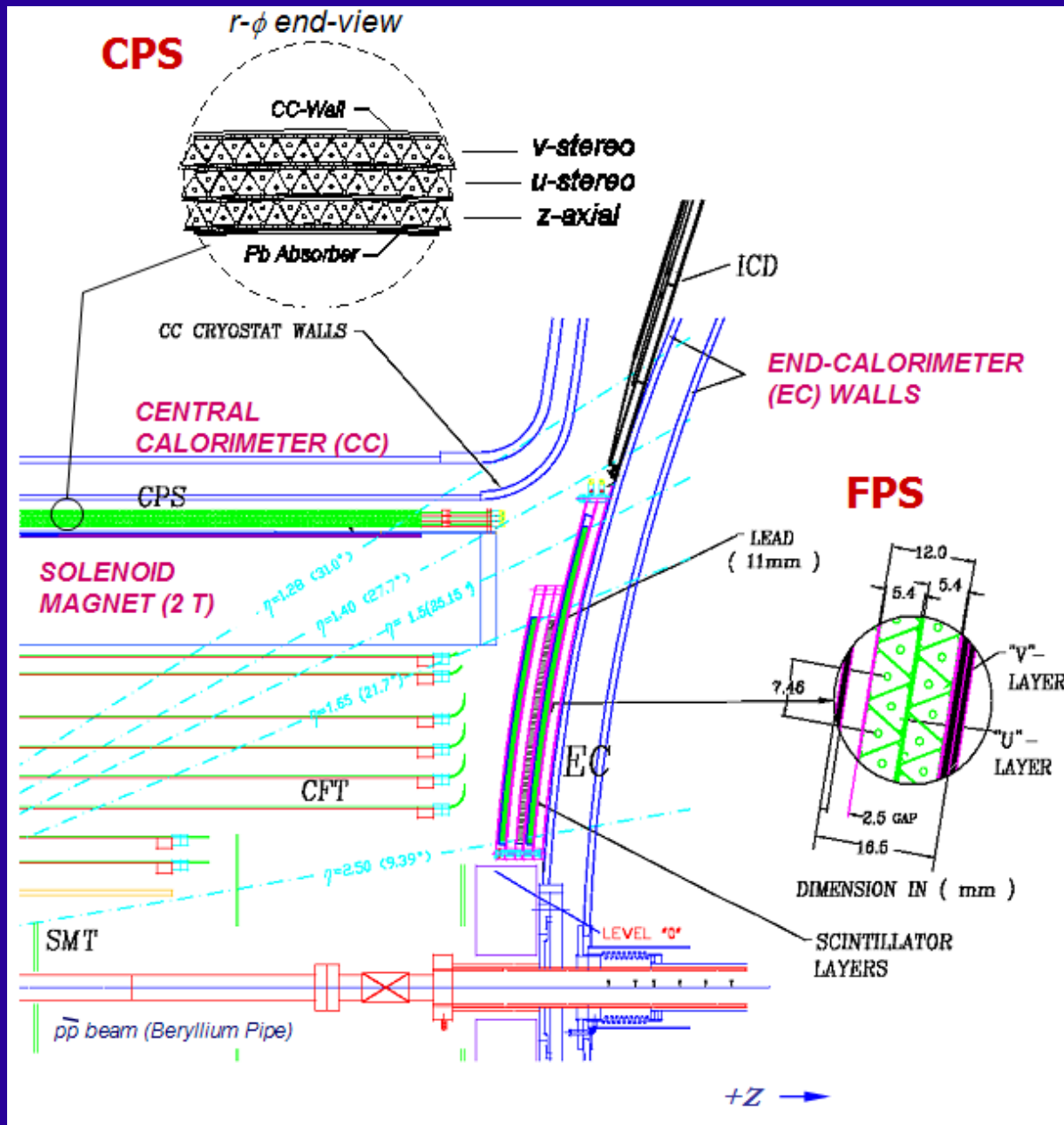

- Silicon Tracker (SMT)
- Fiber Tracker (CFT)
- 2T solenoid
- Detect charged particles and measure their momentum.

D0 Tracking

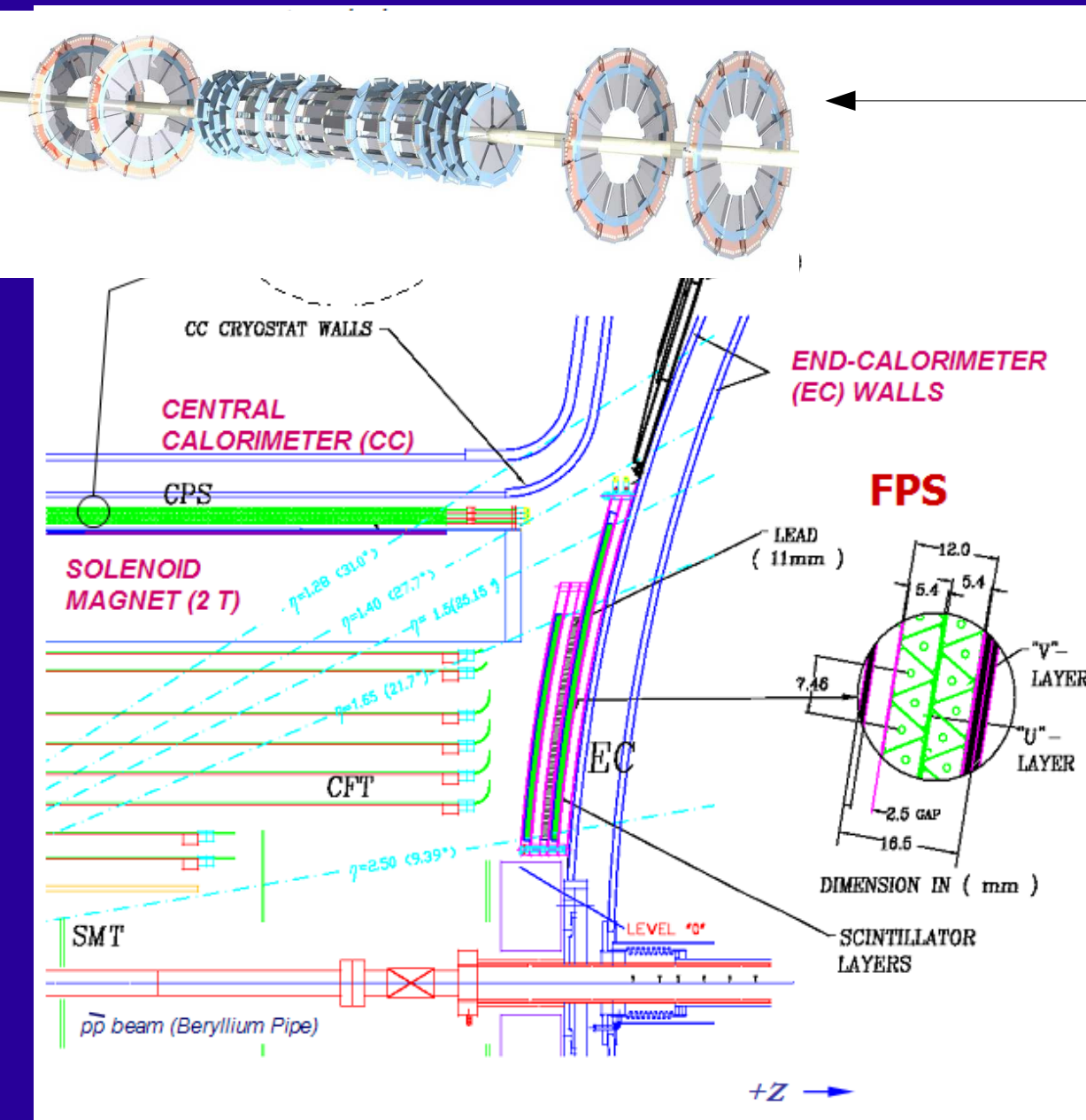

- Silicon Tracker (SMT)
- Fiber Tracker (CFT)
- 2T solenoid
- Detect charged particles and measure their momentum.

Measuring the Charge (I):

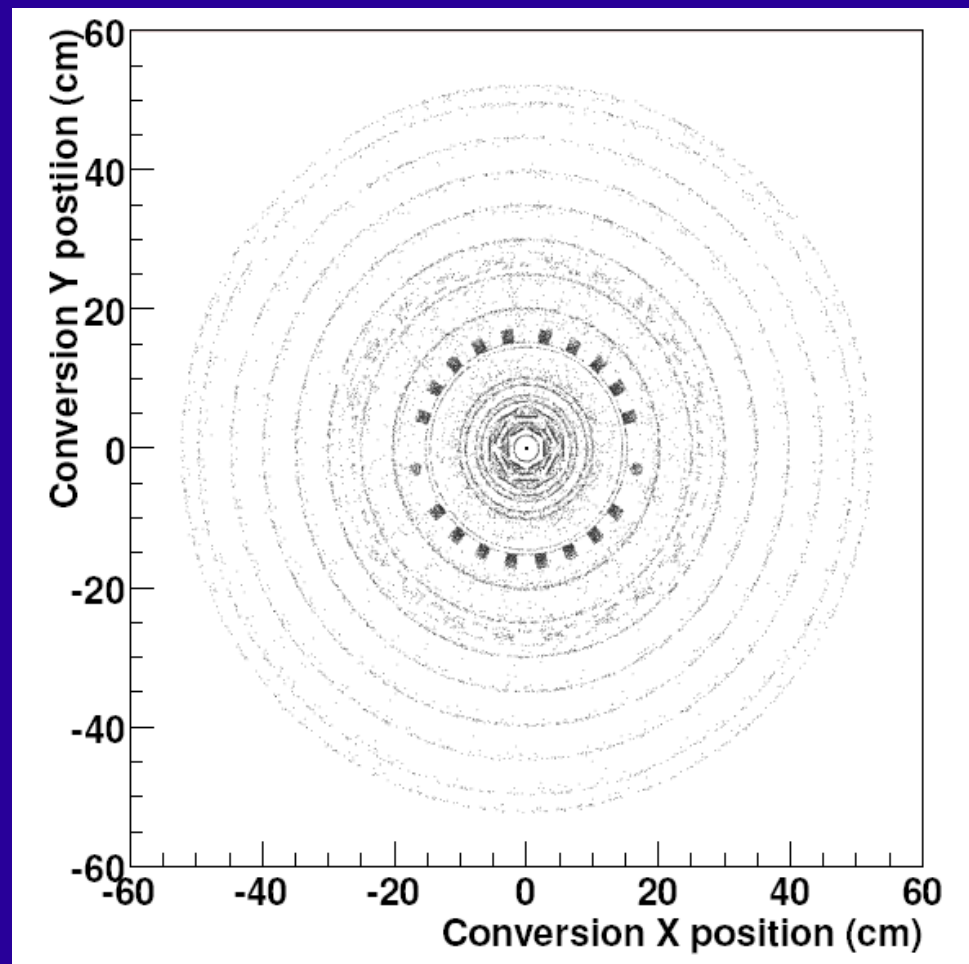

- Here's another view of the D0 tracker. What you see is all of the additional active/inactive material that complicates the charge measurement.

What about material?

- Electrons can (and do) interact with the material of the tracker (in part, that's how you track them).
- However, electron bremsstrahlung can lead to tracks which aren't nicely helical, they can have kinks. Every kink is an opportunity to:
 - A.) Stop tracking, or lose the track.
 - B.) Ruin your track fit, or skew parameters.
- You can also get TRIDENTS (electron interacts with material, emits a high energy photon, which converts. You then reconstruct three tracks, or fit one track to a weird subset of the three sets of hits).
- These problems only get worse with MORE MATERIAL.

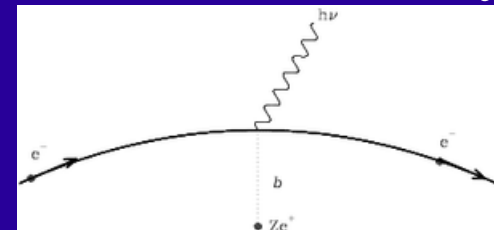

More graphically:

- So here's what actually happens, complete with labels.
- Here is the actual electron track, which originated from the collision. Note negative charge.
- This is cartoonishly enlarged, in reality, all these particles are very close together.

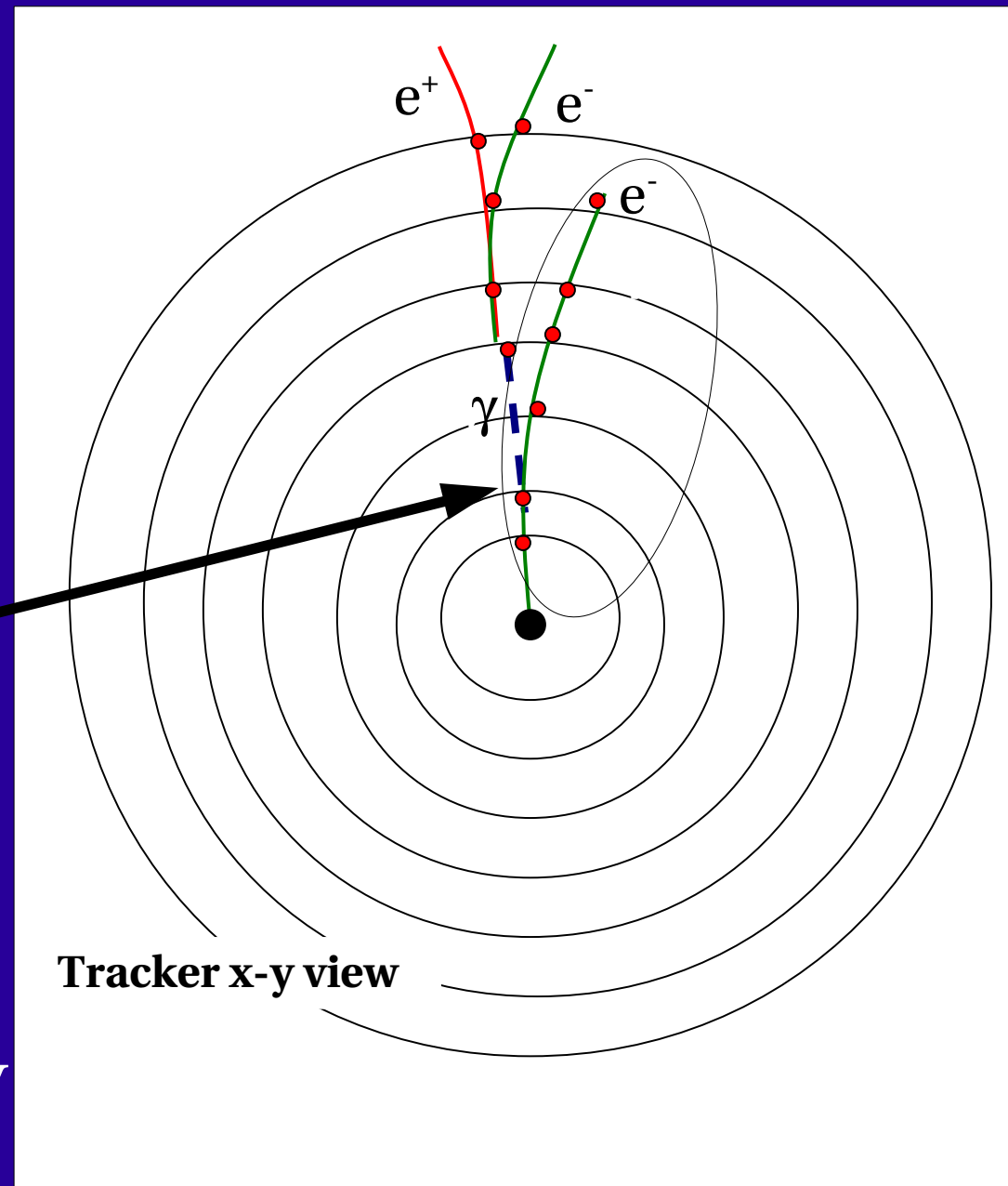

More graphically:

- Here's what happens without the information about the particles. Now all you have are the hits.

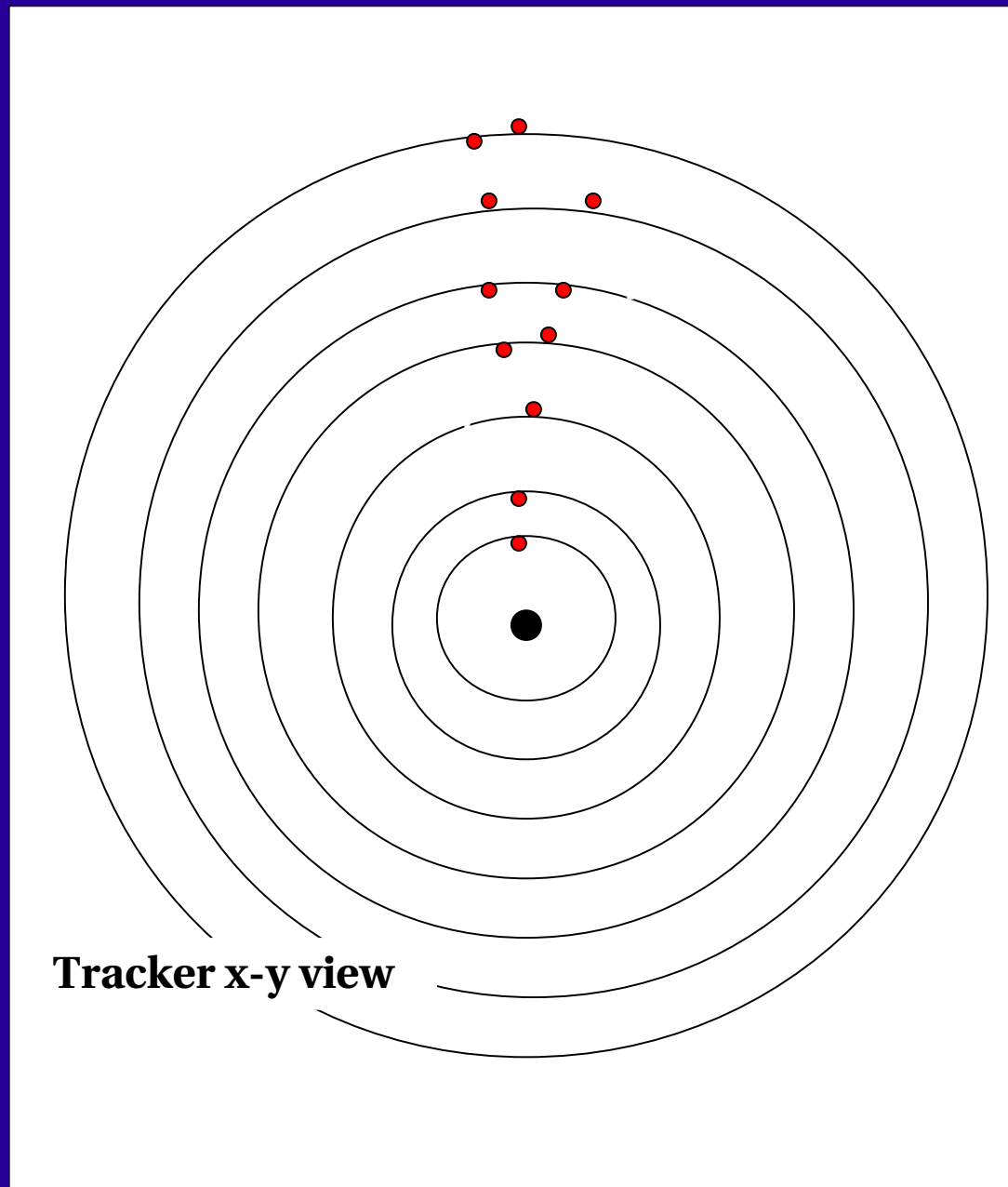

More graphically:

- Here's what happens without the information about the particles. Now all you have are the hits.
- And you run pattern recognition. It picks what IT thinks are a logical set. Which is now positive charge.

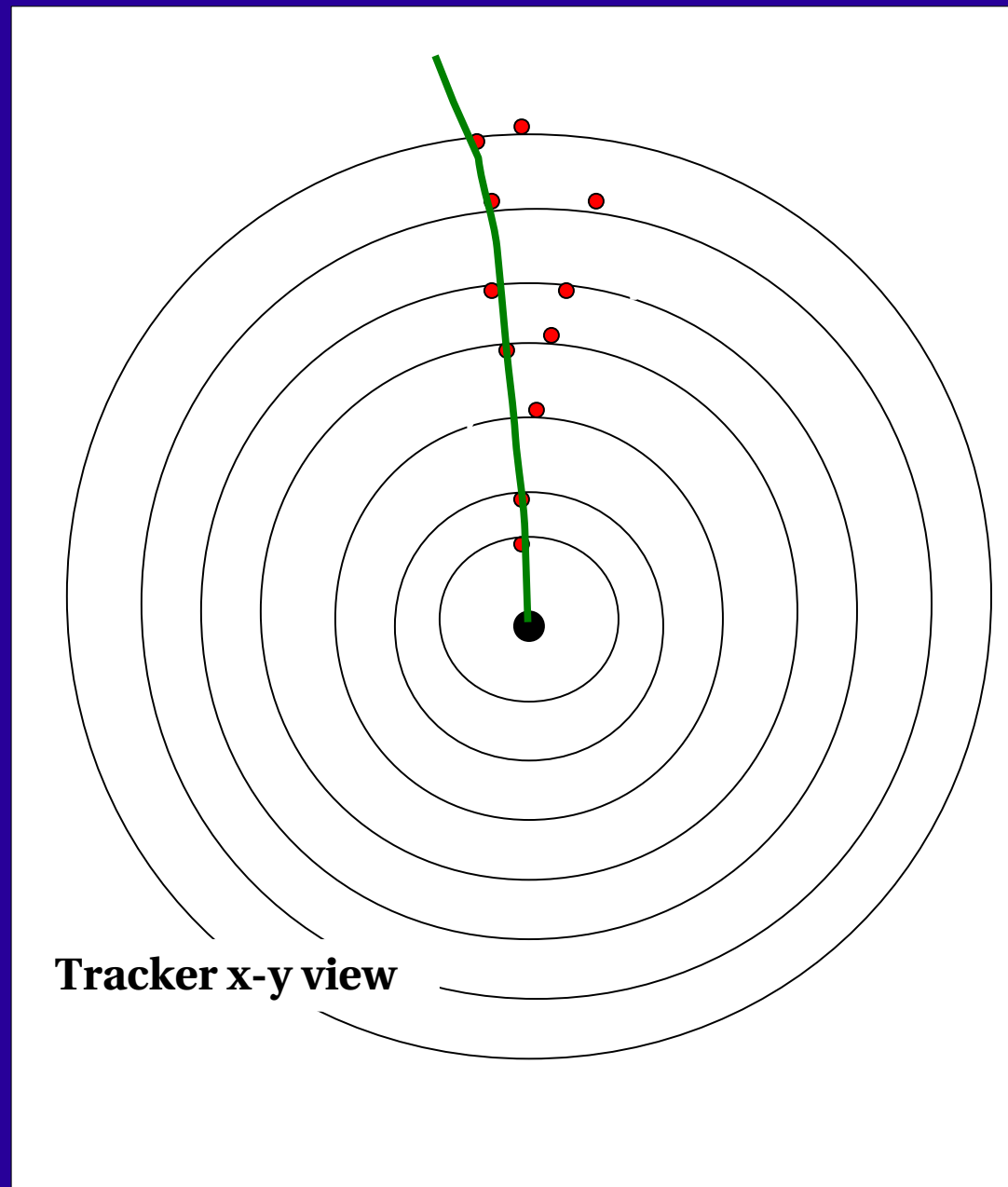

More graphically:

- Here's what happens without the information about the particles. Now all you have are the hits.
- And the pattern recognition picks what IT thinks are a logical set.
- And now since I used the inner hits, I completely lose the other track.
- Thus what is in reality an electron is identified as a positron.

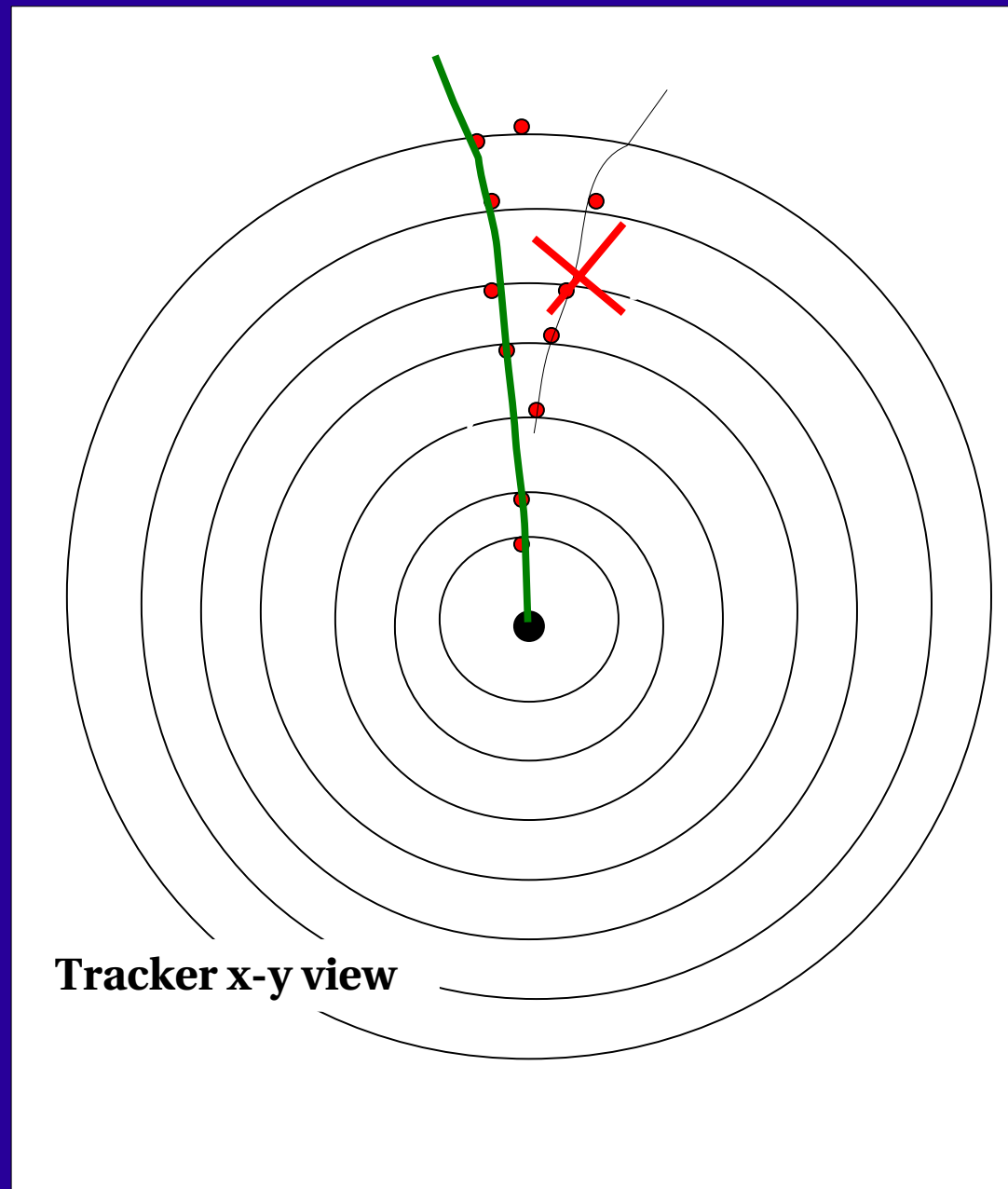

Measuring the Charge (II):

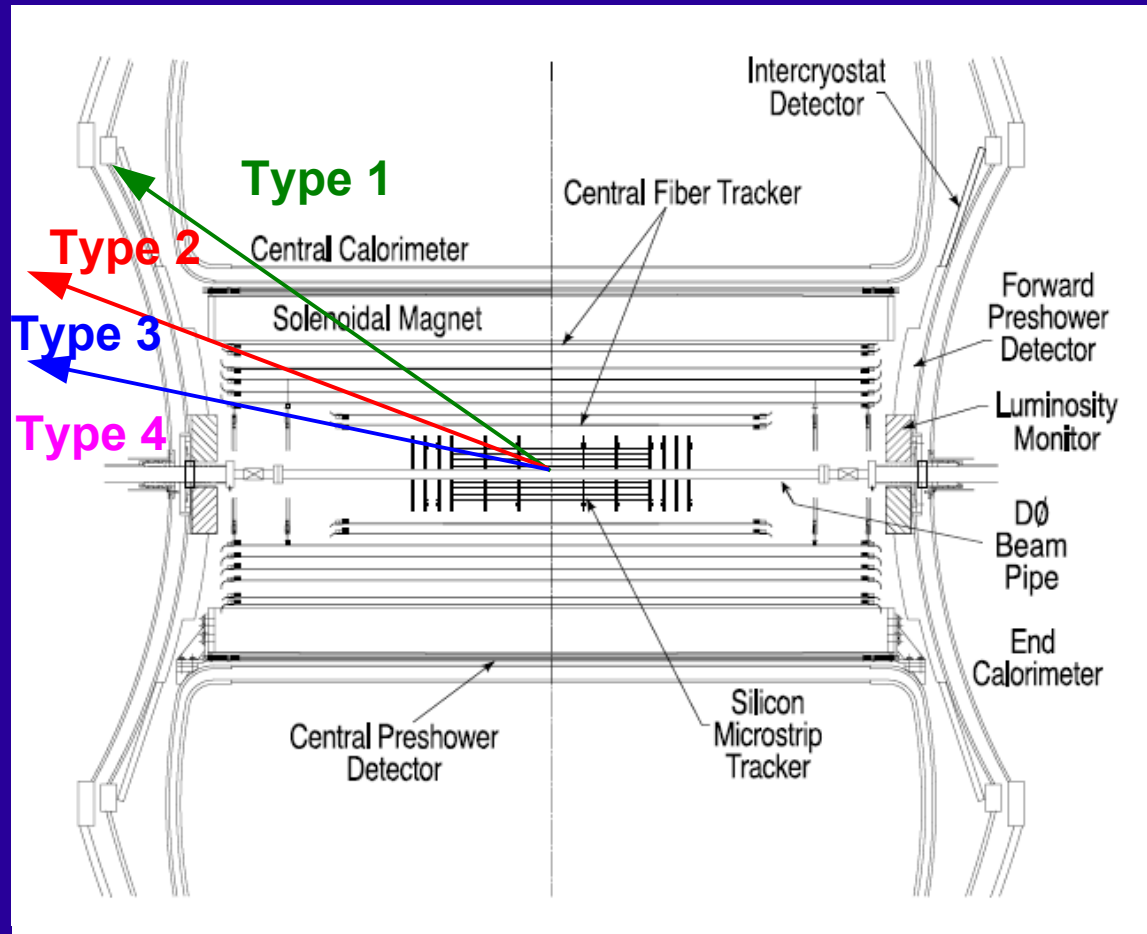

- We split different tracks into different types based on possible measurements in the different tracking devices, and material.

Measuring the Charge (III):

Z^0

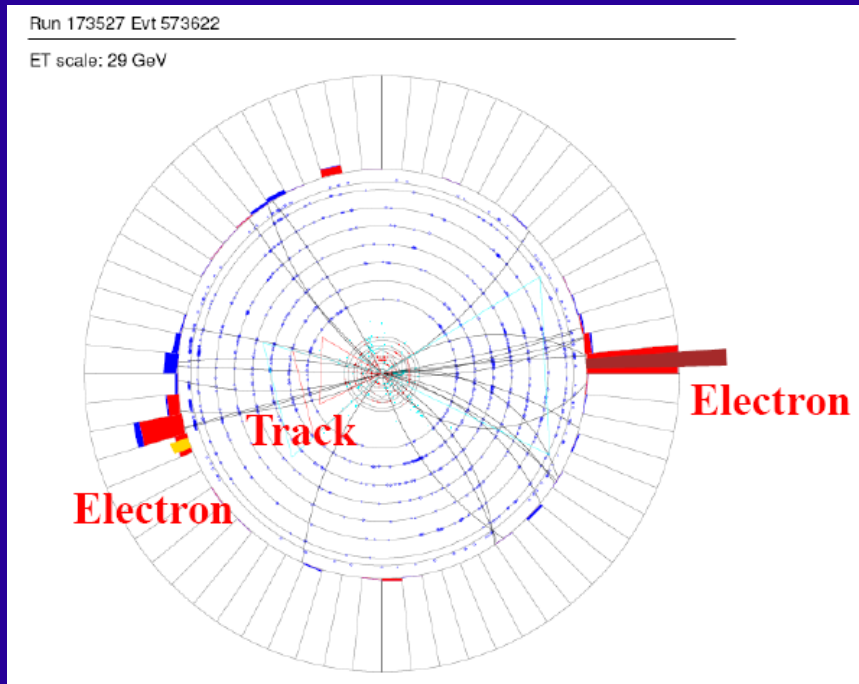
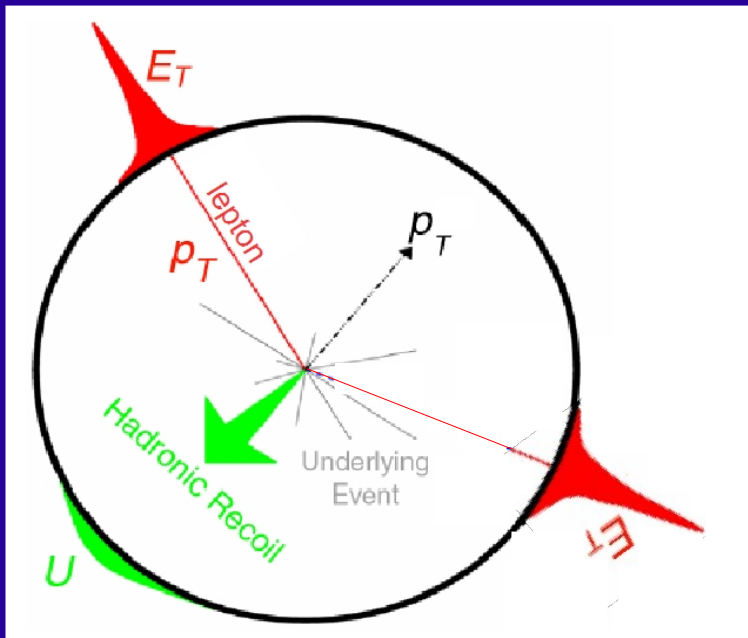

- Take $Z^0 \rightarrow ee$ events:
 - Place strict quality cuts on one track, ensuring that the charge is measured correctly.
 - Examine other track, comparing charge to the well measured one (since should be opposite).
 - Can reconstruct mass, ensuring that these ARE Z^0 events.

Measured Charge Misid:

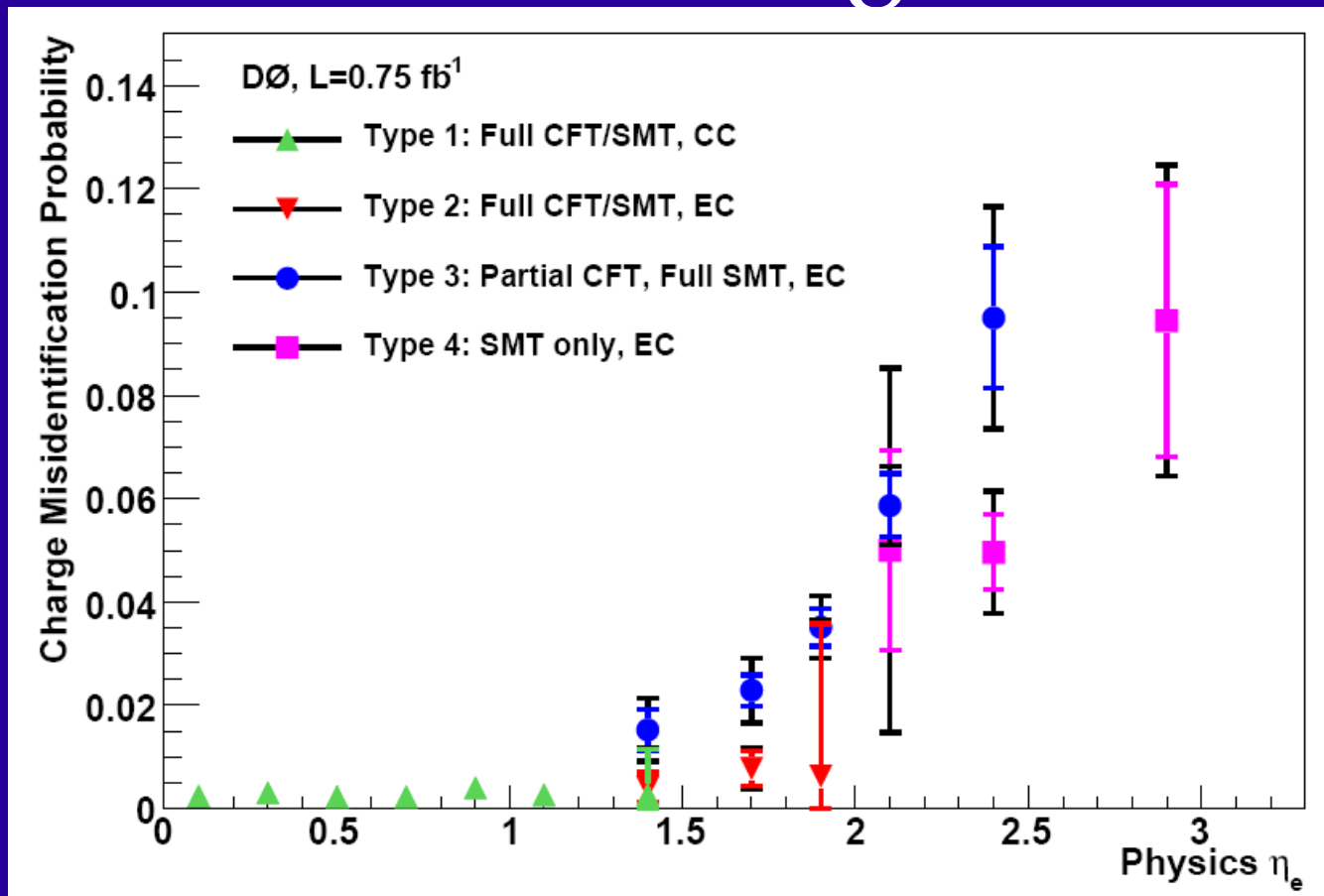

- Measure the misidentification in data for each different type. We'll also measure the asymmetry, efficiencies, and backgrounds separately, and combine at the end.

Wrapping up:

- We use a very tight selection for the electrons themselves which minimizes electron misidentification backgrounds.
- We study the efficiencies, and the backgrounds as a function of the charge, and find them to be symmetric. Since the efficiencies are symmetric, (after background subtraction) the final asymmetry is in terms number of electron events (the efficiencies cancel).

$$A(\eta_i) = \frac{d\sigma(l^+)/d\eta - d\sigma(l^-)/d\eta}{d\sigma(l^+)/d\eta + d\sigma(l^-)/d\eta}$$



$$A(\eta_e) = \frac{N^{\ell^+}(\eta) - N^{\ell^-}(\eta)}{N^{\ell^+}(\eta) + N^{\ell^-}(\eta)}$$

- Also, the magnetic field is regularly changed so that half the data is with the 'forward' configuration, and half is with the 'reverse', further limiting possible biases.

Final Asymmetry:

- Final measured asymmetry over the entire coverage of the DØ experiment, in two bins of electron E_T .
 - Once can see good agreement for low E_T .

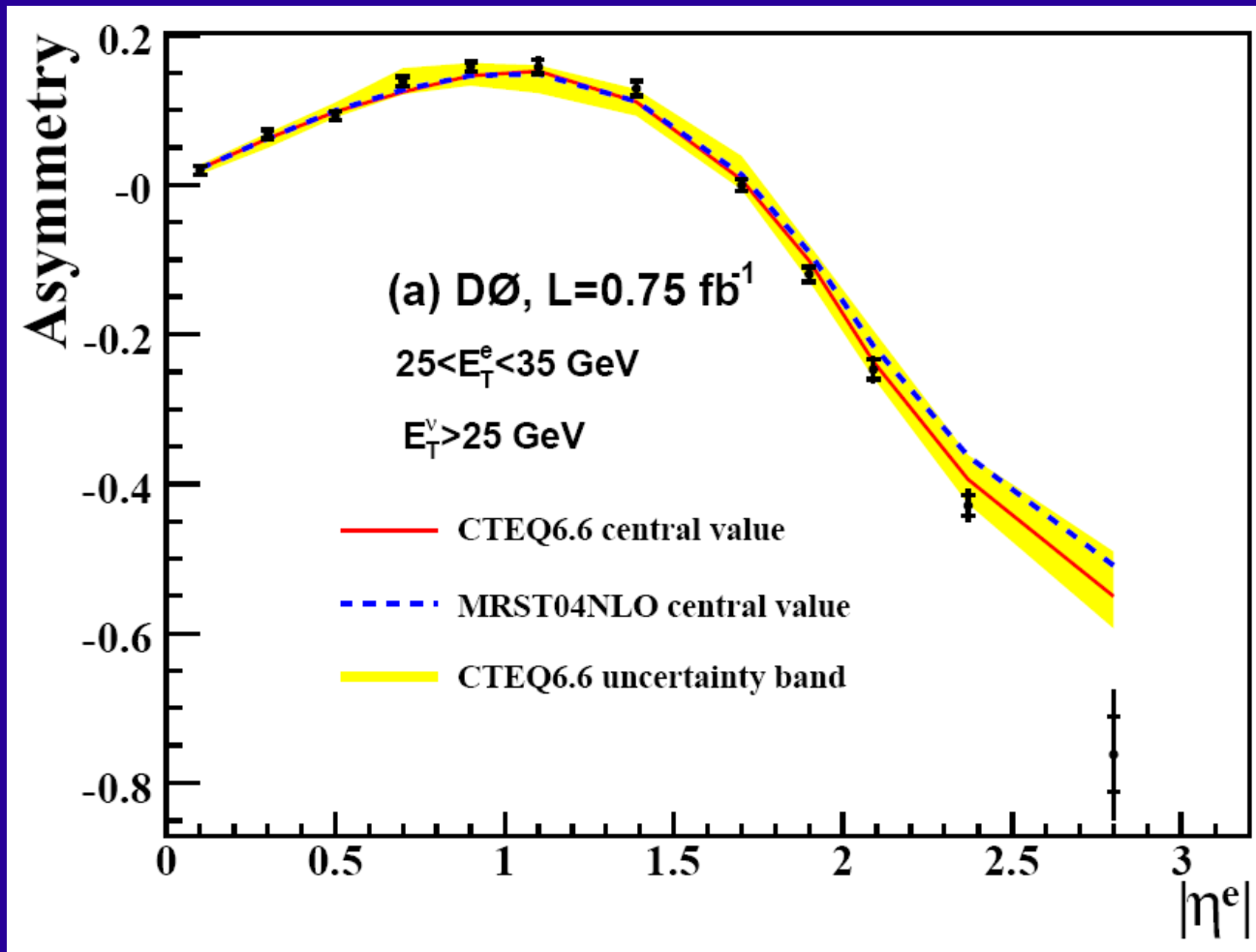

Final Asymmetry:

- Final measured asymmetry over the entire coverage of the D0 experiment, in two bins of electron E_T .
 - Surprisingly the u-quark isn't carrying as much momentum as we thought.

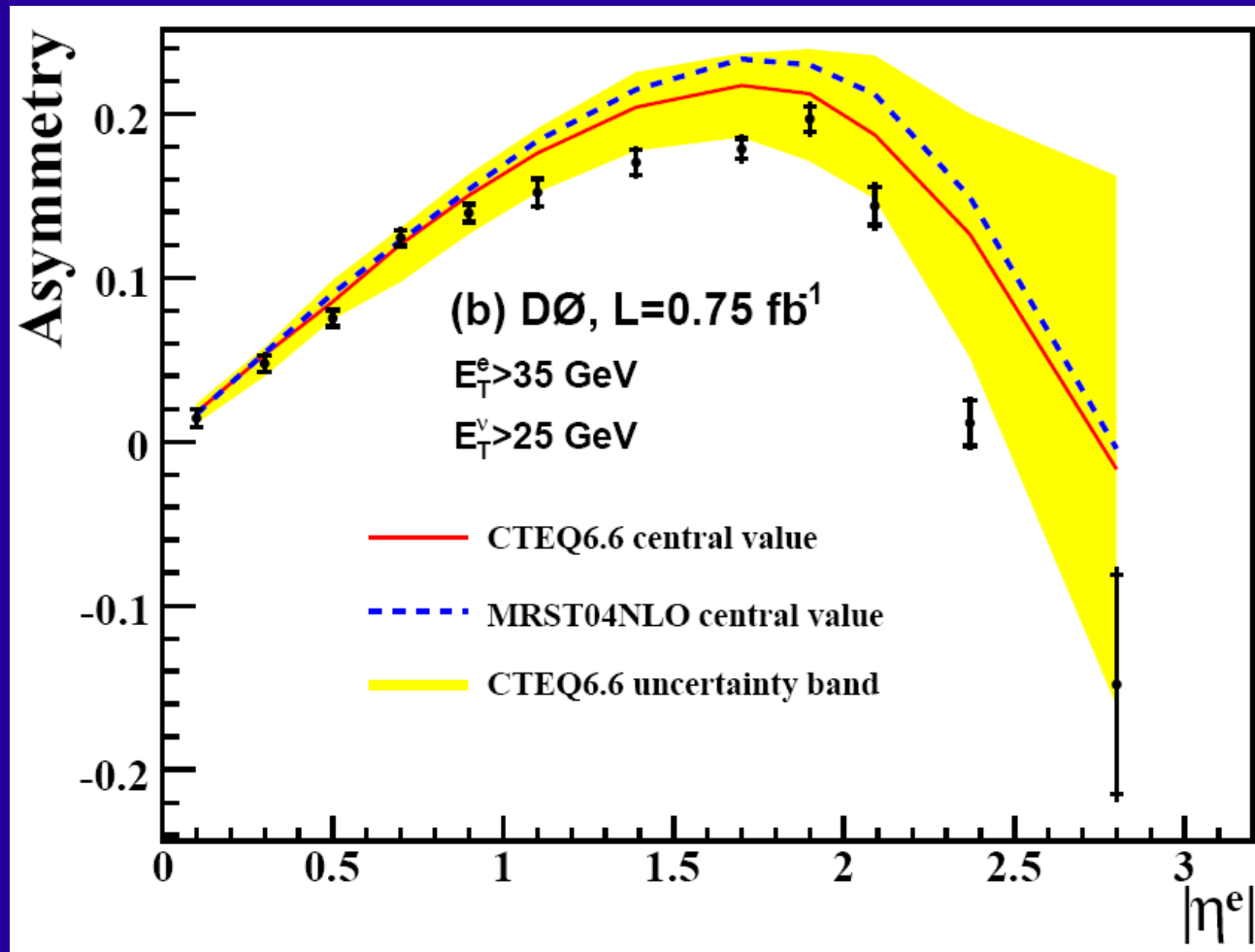

So we've used the W ...

- We've used the W as a means to probe the distribution of momentum within the proton. Which is important.
- Now we'll take a turn: We'll study the structure of the Standard Model itself, by observing how the W interacts with the photon.

IF there's a Higgs...

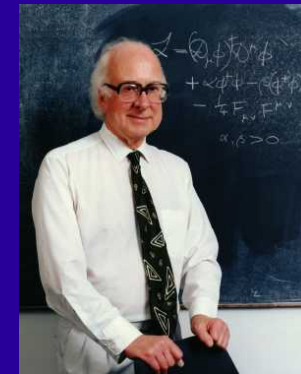
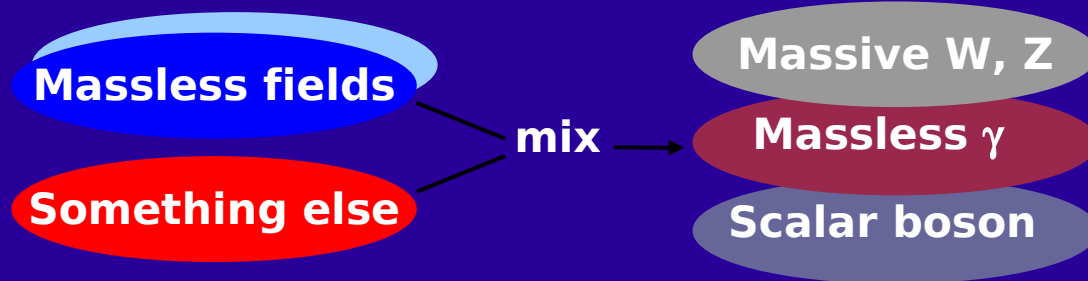

The "Higgs Mechanism"

- Once you accept that there IS a Higgs, then the strength with which the W, Z and γ interact with each other is fixed.
- If there is no Higgs however, then these may not be fixed.
- We can test these interactions by studying the production of pairs of bosons. For example WW, WZ, $W\gamma$.
- $W+\gamma$ is an interesting case. If the strength of the interaction increases with energy, then one should see it in the energy of the photons!

$W\gamma$ Goals:

- Study the final state of $W+\gamma$:
 - Interference structure: These three diagrams interfere, which leads to a distinct angular distribution.
 - Transverse Energy: if new physics takes over above a certain threshold, then the spectrum of photons produced should change. Specifically there should be MORE high energy events.

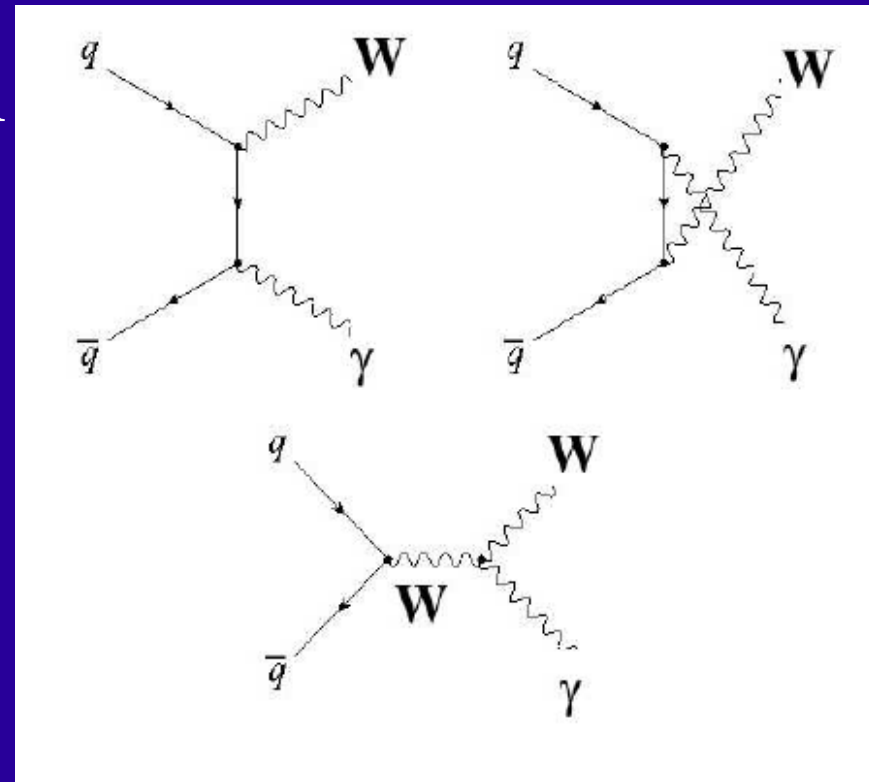

Finding Photons:

- A different challenge than finding electrons.
 - No signal in the tracker.
- Only one detector leaves one at the mercy of a host of instrumental challenges.
 - False signals (instrumental noise)
 - Fake signals (particles which could appear to be photons, but in reality are not)
- I'll say a few words here, but if you have questions, ask!

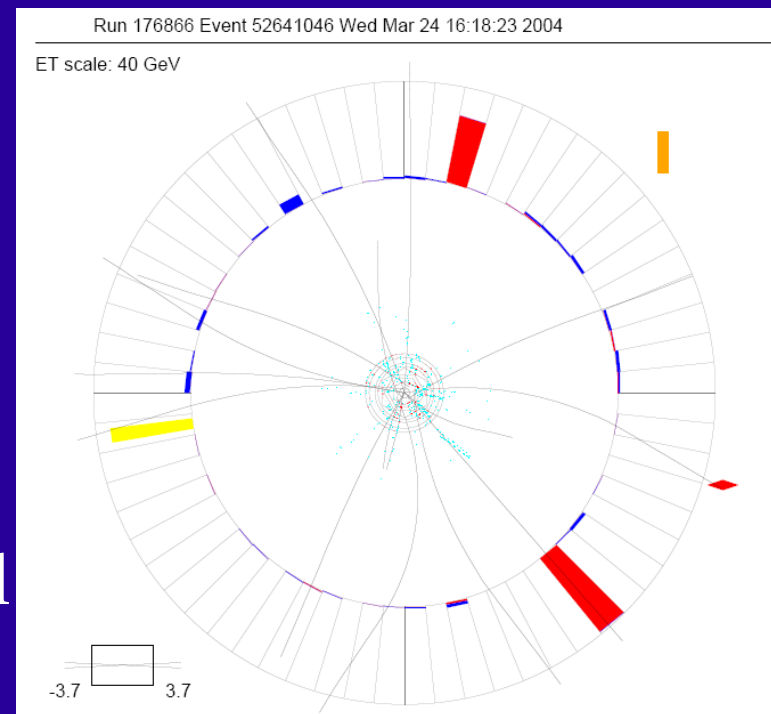

DØ Calorimetry

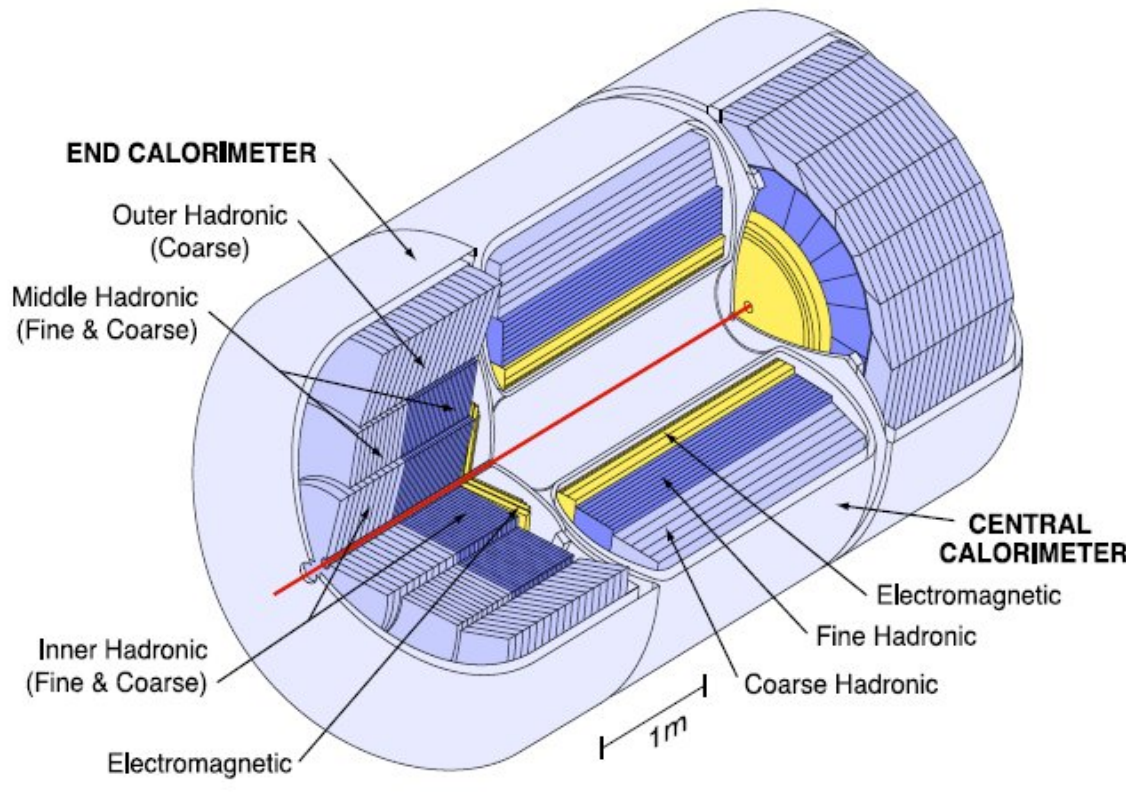

- LAr/U calorimeter.
- Important note: Very good coverage, longitudinal segmentation.
- Preshowers immediately after tracking.

D0 Calorimetry

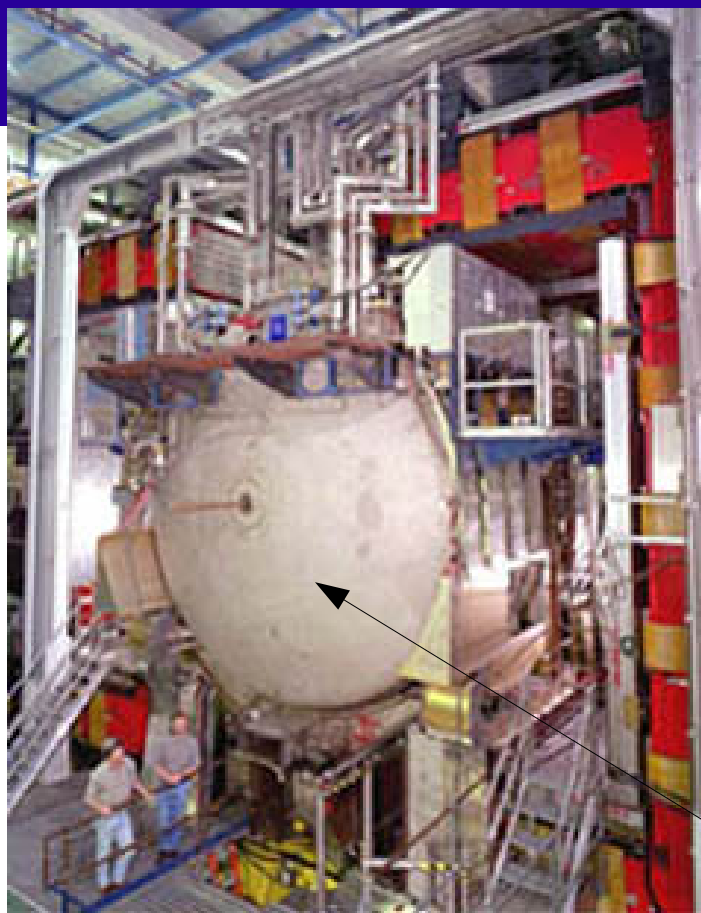

Electromagnetic

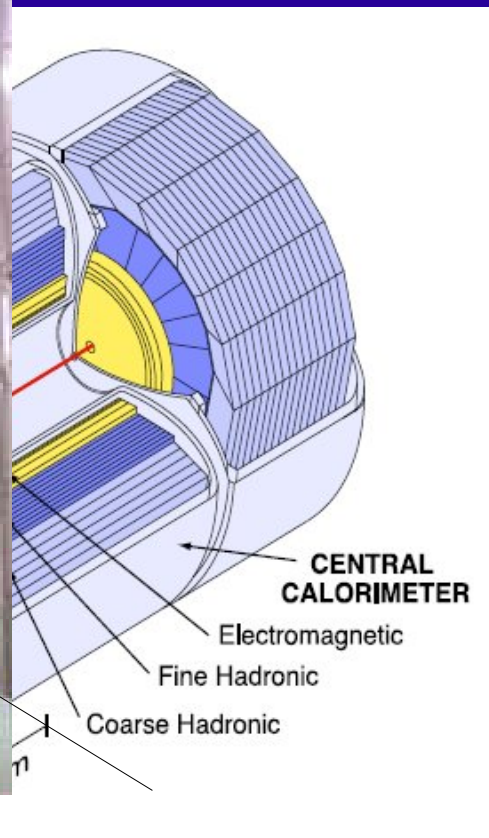

Central Calorimeter

- LAr/U calorimeter.
- Important note: Very good coverage, longitudinal segmentation.
- Preshowers immediately after tracking.

DØ Calorimetry



Electromagnetic

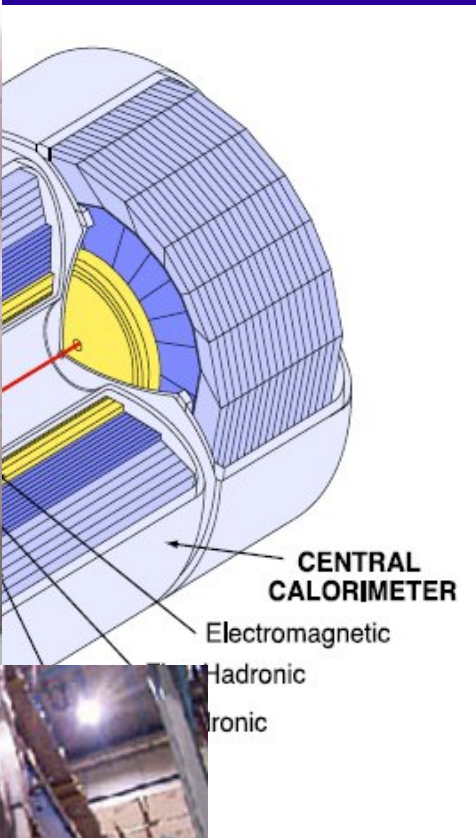

Endcap calorimeter

- LAr/U calorimeter.
- Important note: Very good coverage, longitudinal segmentation.
- Preshowers immediately after tracking.

D0 Calorimetry



Electromagnet

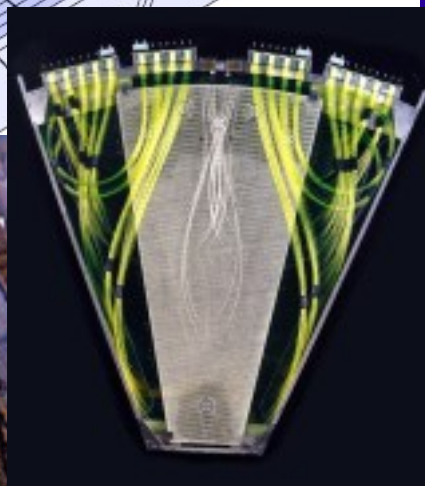
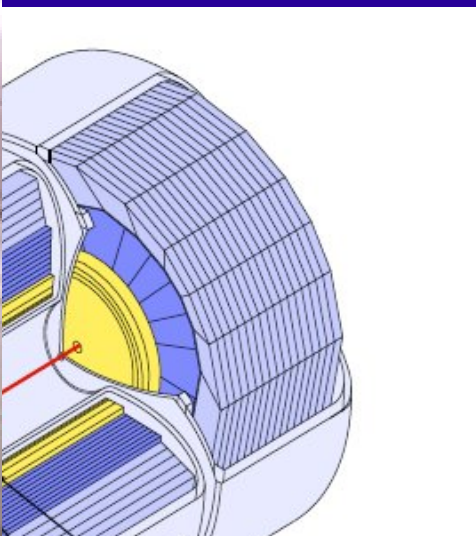

calorimeter

- LAr/U calorimeter.
- Important note: Very good coverage, longitudinal segmentation.
- Preshowers immediately after tracking.

Additional Effort for γ

- Preshowers are effectively more calorimetry, and can give more rejection.

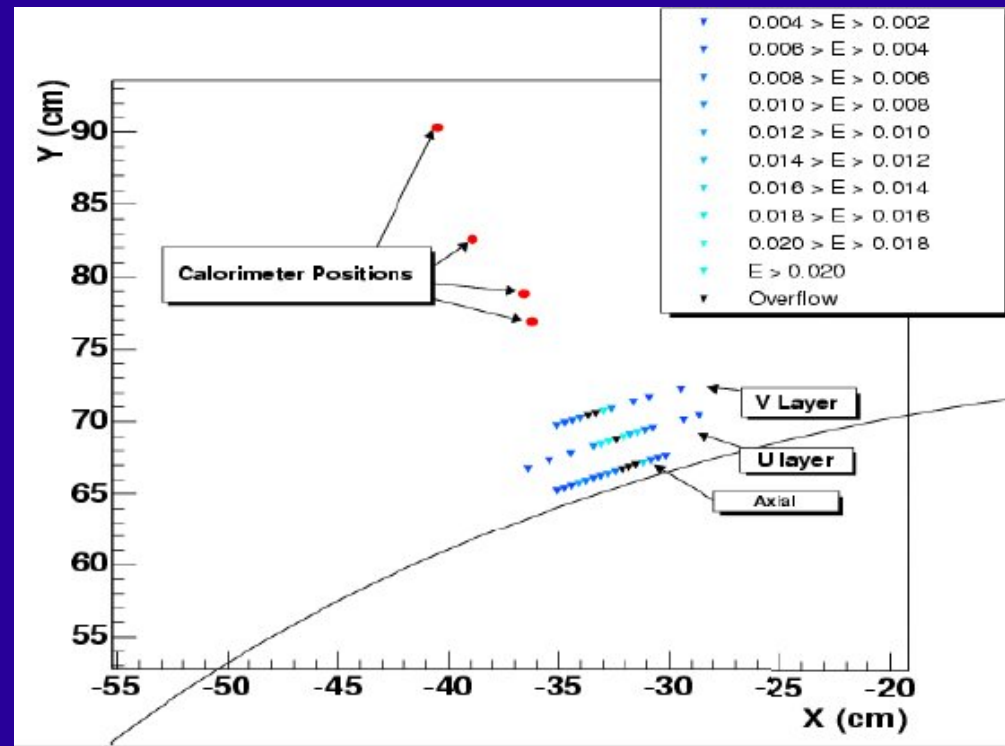
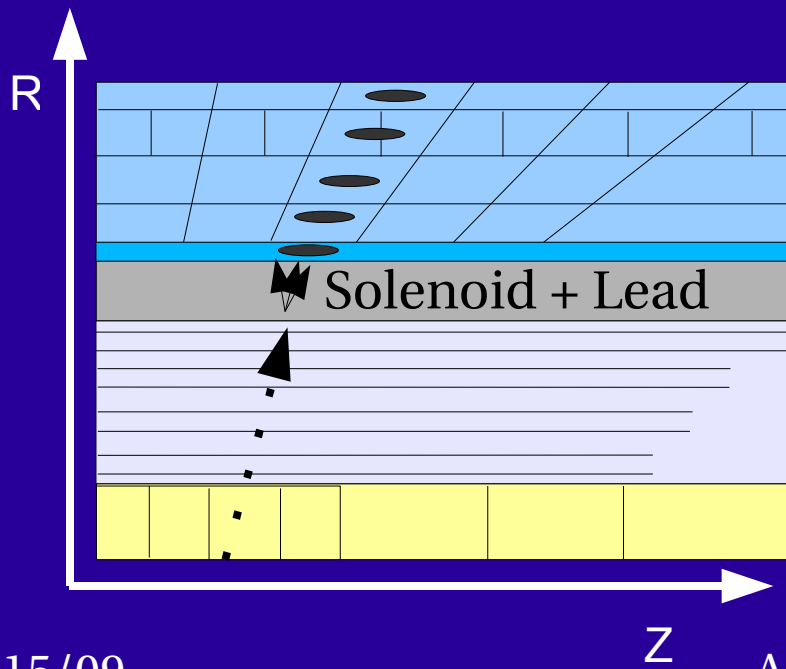

- Since there's several layers of calorimeter, we can “point” photons back to their origin.

In situ measurement:

- One can use $Z \rightarrow ll$ to study leptons and test how well the algorithms work.
- Similarly, one may use $Z\gamma \rightarrow ll\gamma$ to get a picture of how well the photon algorithms work.

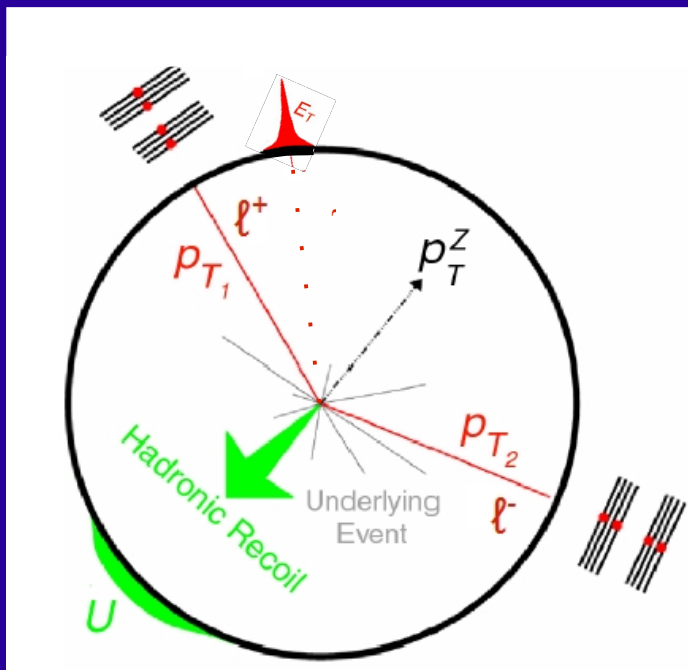

$Z^0 \gamma$

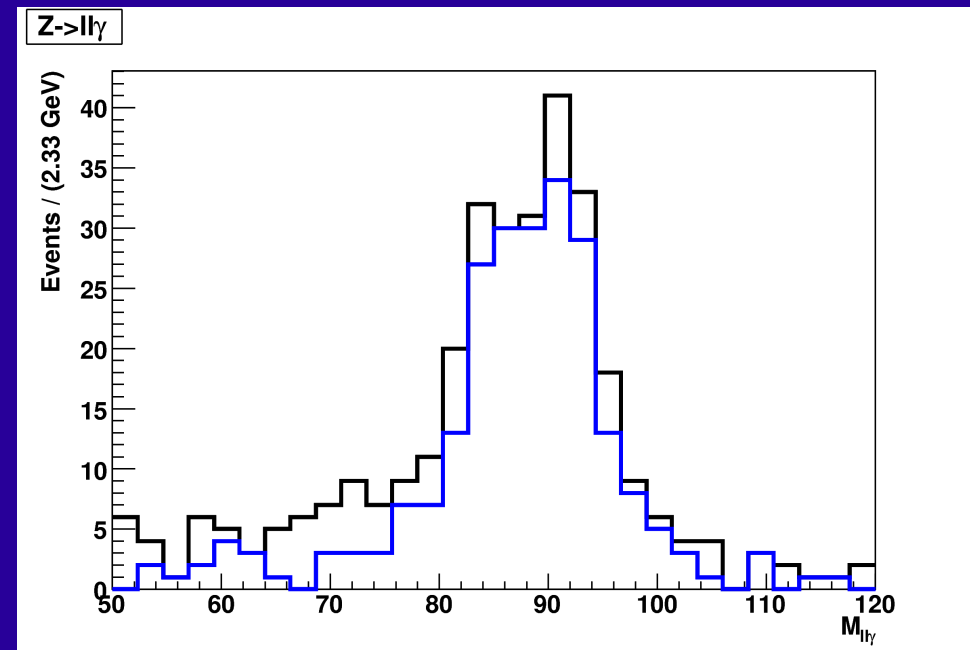

Angular distribution?

No Interference

Interference

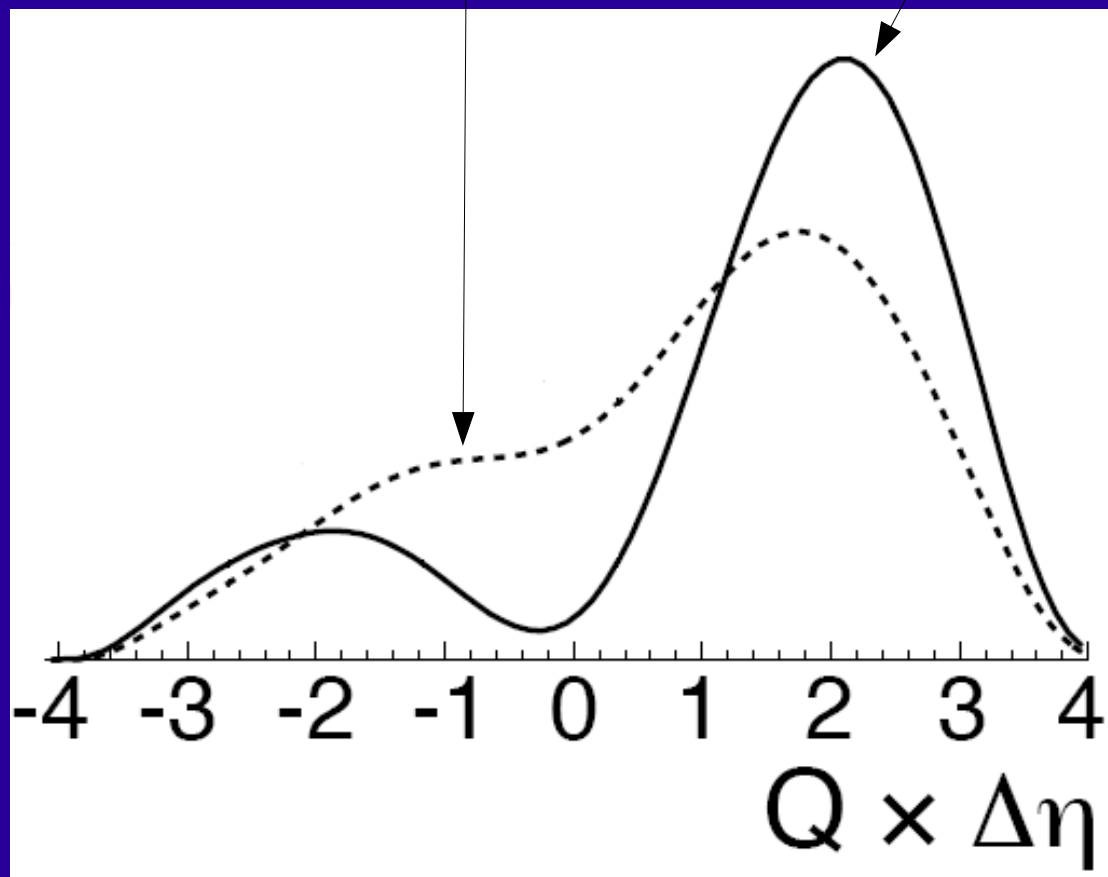

- Basically looking at an angular difference between the photon and lepton (in this case the rapidity difference).
- Nice graceful dip if there is interference.
- Big lump if not.

Angular distribution?

No Interference

Interference

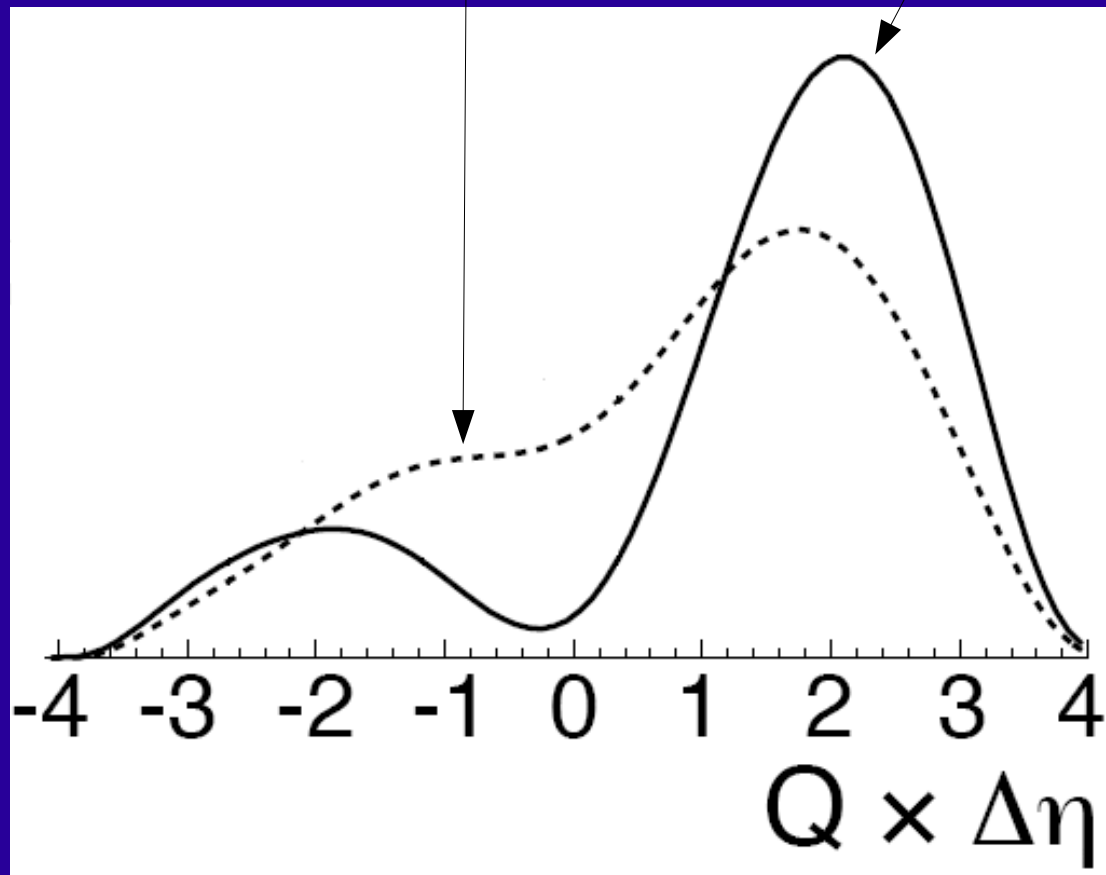

- Notice that this distribution is asymmetric? This is the W charge asymmetry again, just in a different final state, and with both charges combined.

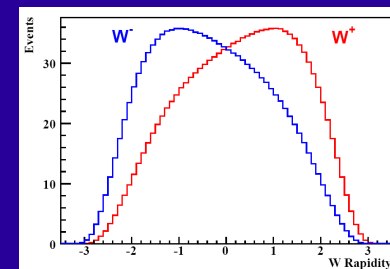

Our actual measured distribution:

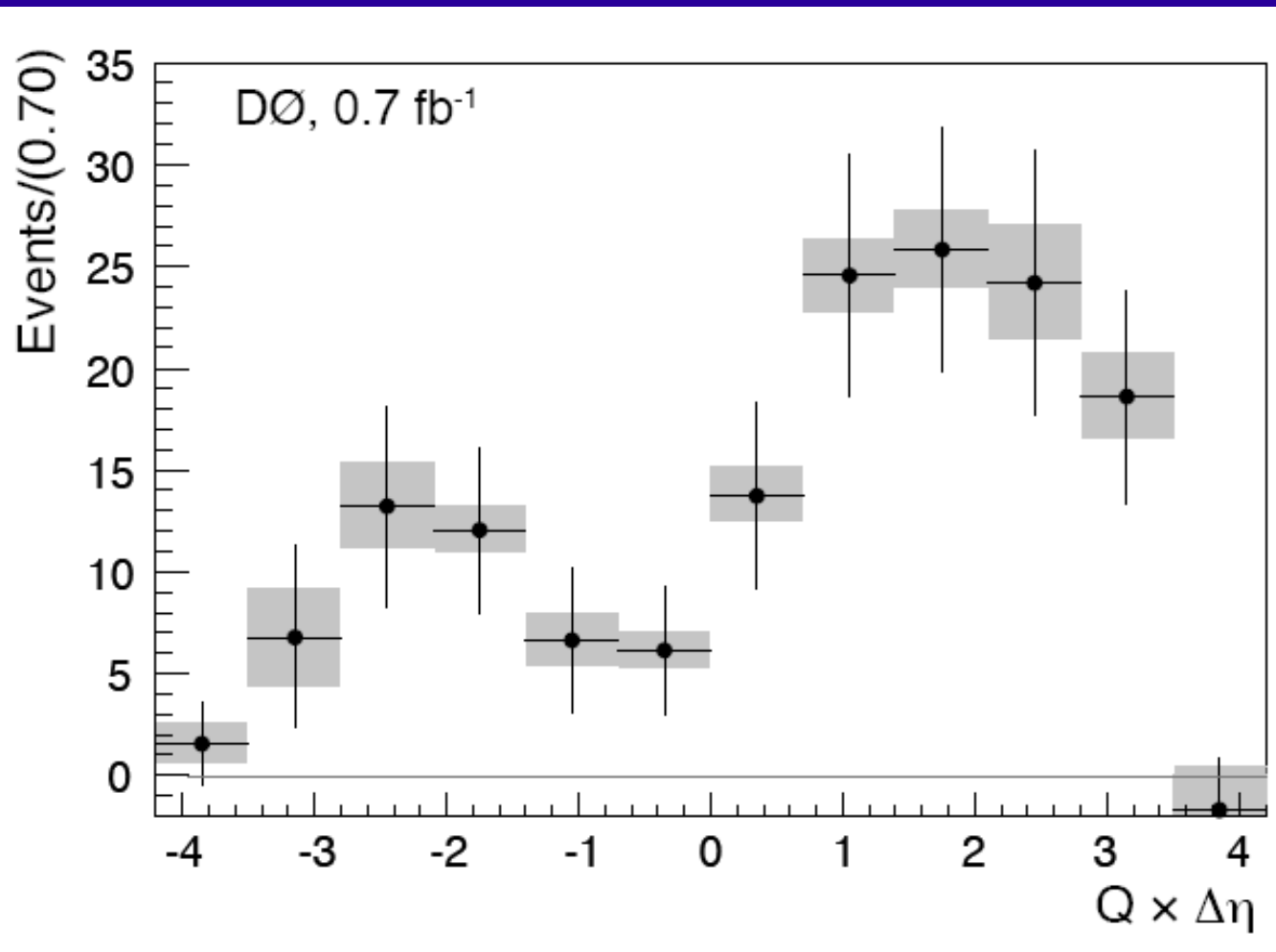

- Simply a beautiful test, displays the expected behavior.
- First measurement of this distribution, requires large photon acceptance.

W γ Result

- Rate is in good agreement with Standard Model.
- Better still, the spectrum of the photons is also in good agreement.

Photons around 200 GeV! Recall, visible light is only 2-3 eV.

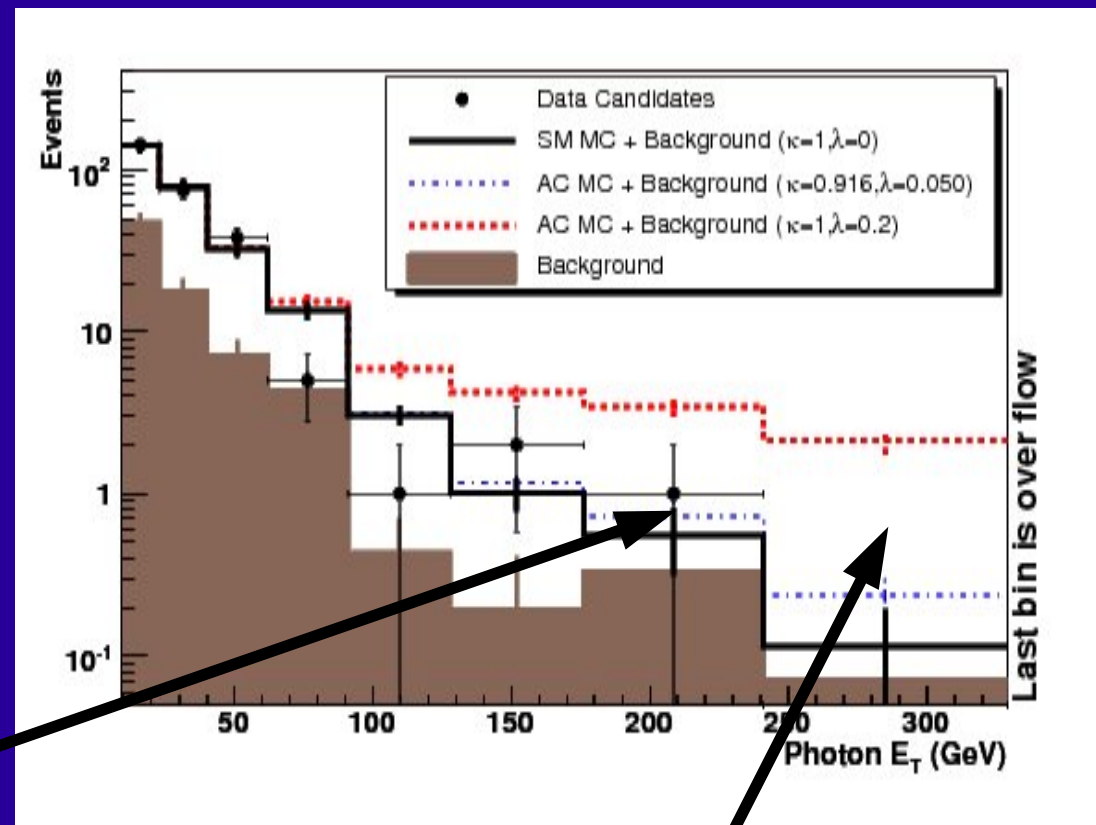

Here's where you would see an excess if the strength of the interaction was increasing.

Diboson Summary:

- As I said previously, testing all of the diboson couplings is important.
- This stands as a one plot summary of the Run II Boson/Diboson measurements.

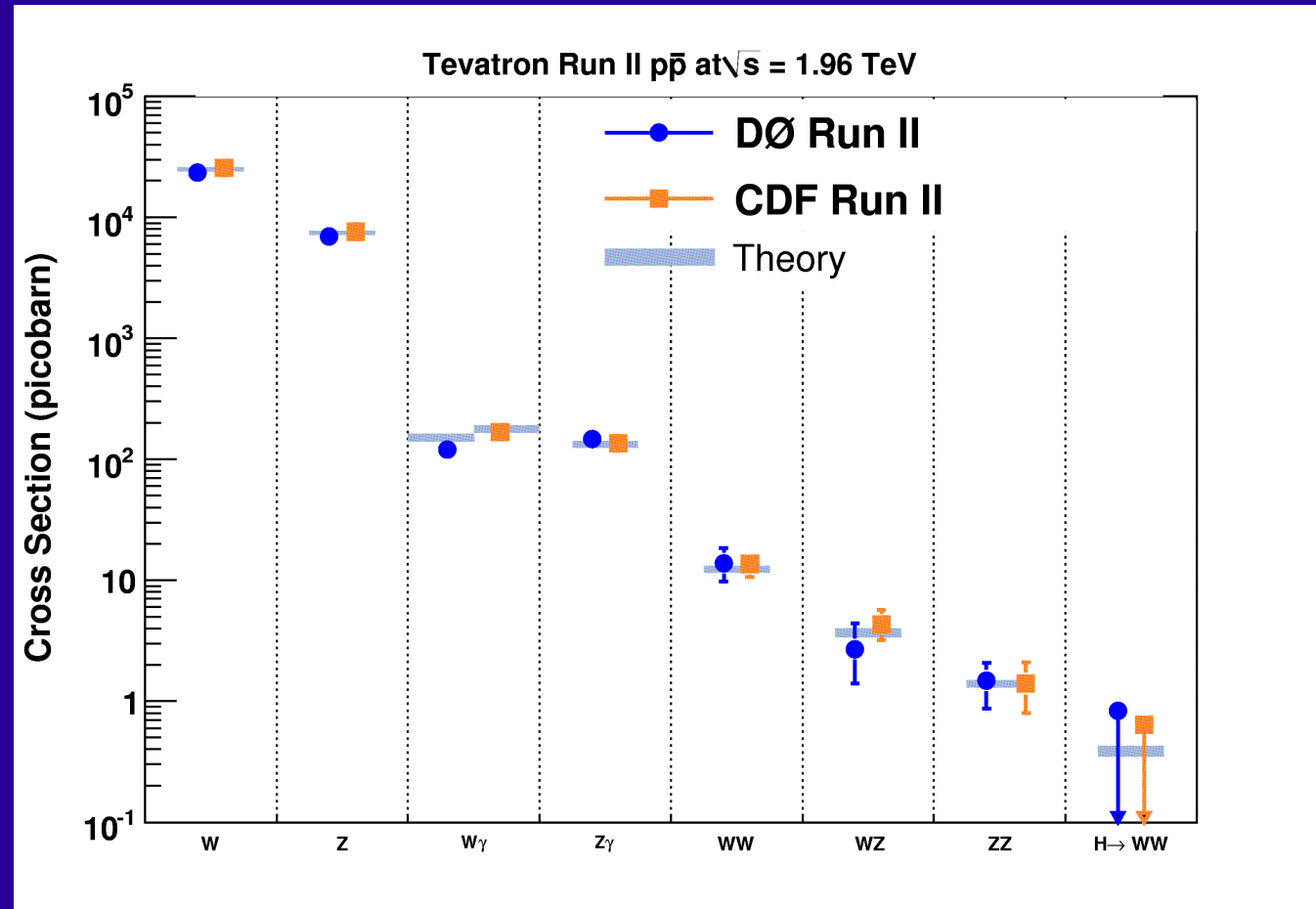

In Summary

- I've shown two studies utilizing the W boson:
 - The first concentrated on what the production of W bosons can tell us about the proton. This information should be useful in making predictions for the LHC.

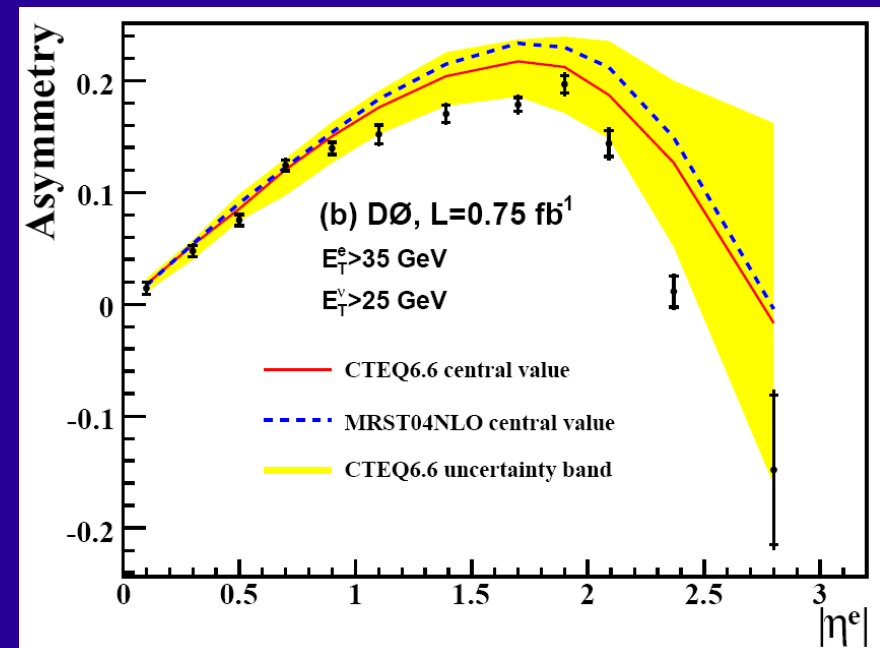

In Summary

- I've shown two studies utilizing the W boson:
 - The first concentrated on what the production of W bosons can tell us about the proton. This information should be useful in making predictions for the LHC.
 - The second concentrated on the more fundamental structure of the Standard Model, in Diboson interactions. This is central to exploring whether our current picture of nature is correct.

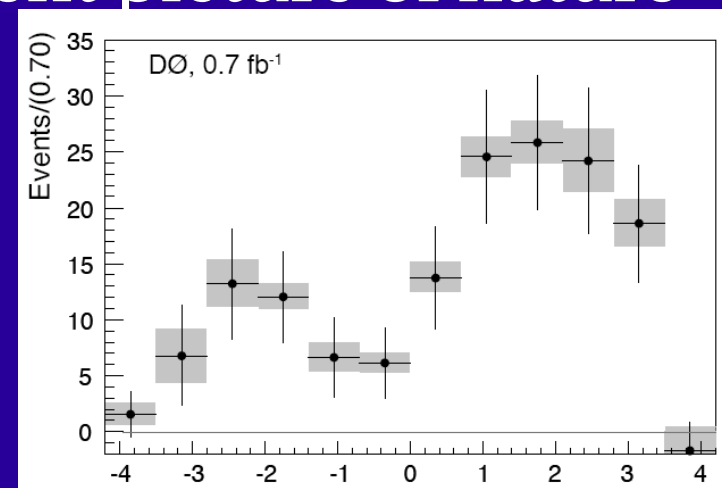

In Summary

- I've shown two studies utilizing the W boson:
 - The first concentrated on what the production of W bosons can tell us about the proton. This information should be useful in making predictions for the LHC.
 - The second concentrated on the more fundamental structure of the Standard Model, in Diboson interactions. This is central to exploring whether our current picture of nature is correct.
- What's next?

The LHC:

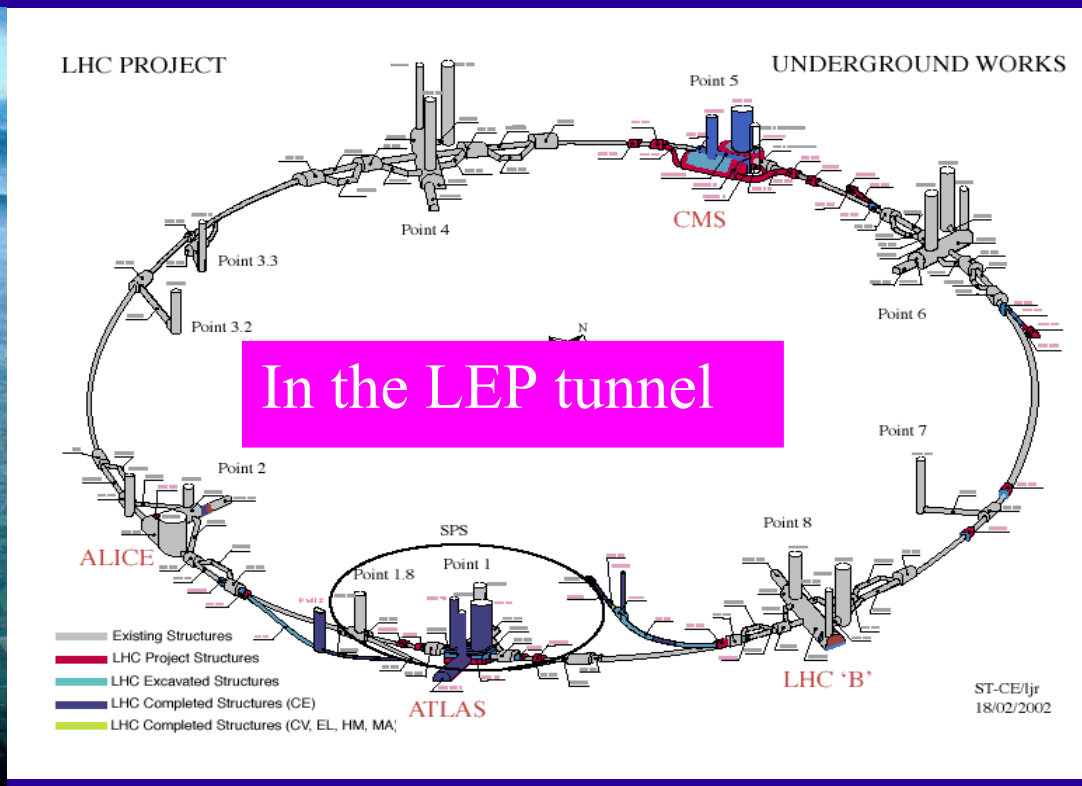
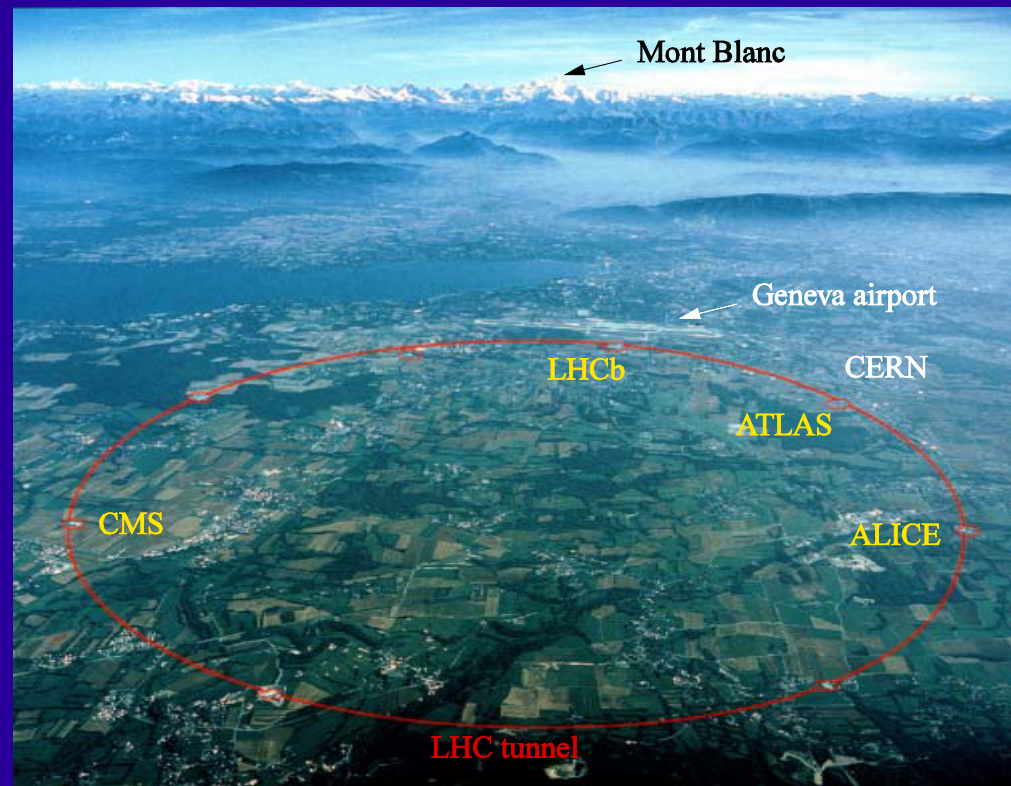

- ★ $pp \sqrt{s} = 14 \text{ TeV}$
- ★ crossing rate 40 MHz (25 ns)
- ★ circumference of 27 km (16.8 miles)

The LHC:

- A factor of seven increase in energy is nothing to sneeze at ($2 \text{ TeV} \rightarrow 14 \text{ TeV}$).
 - This is especially relevant to dibosons, if there is no Higgs, then there must be action here! If there is a Higgs we should see it!
- New detectors, new environment, and some of the same challenges...

The LHC:

- A factor of seven increase in energy is nothing to sneeze at ($2 \text{ TeV} \rightarrow 14 \text{ TeV}$).
 - This is especially relevant to dibosons, if there is no Higgs, then there must be action here!

An example from LHC:



← CMS Tracker has more silicon than any other experiment in history.



→ CMS ECAL is right behind it. Familiar challenge.

Material is actually a WORSE problem for photons than for electrons!

Photons are worth it!

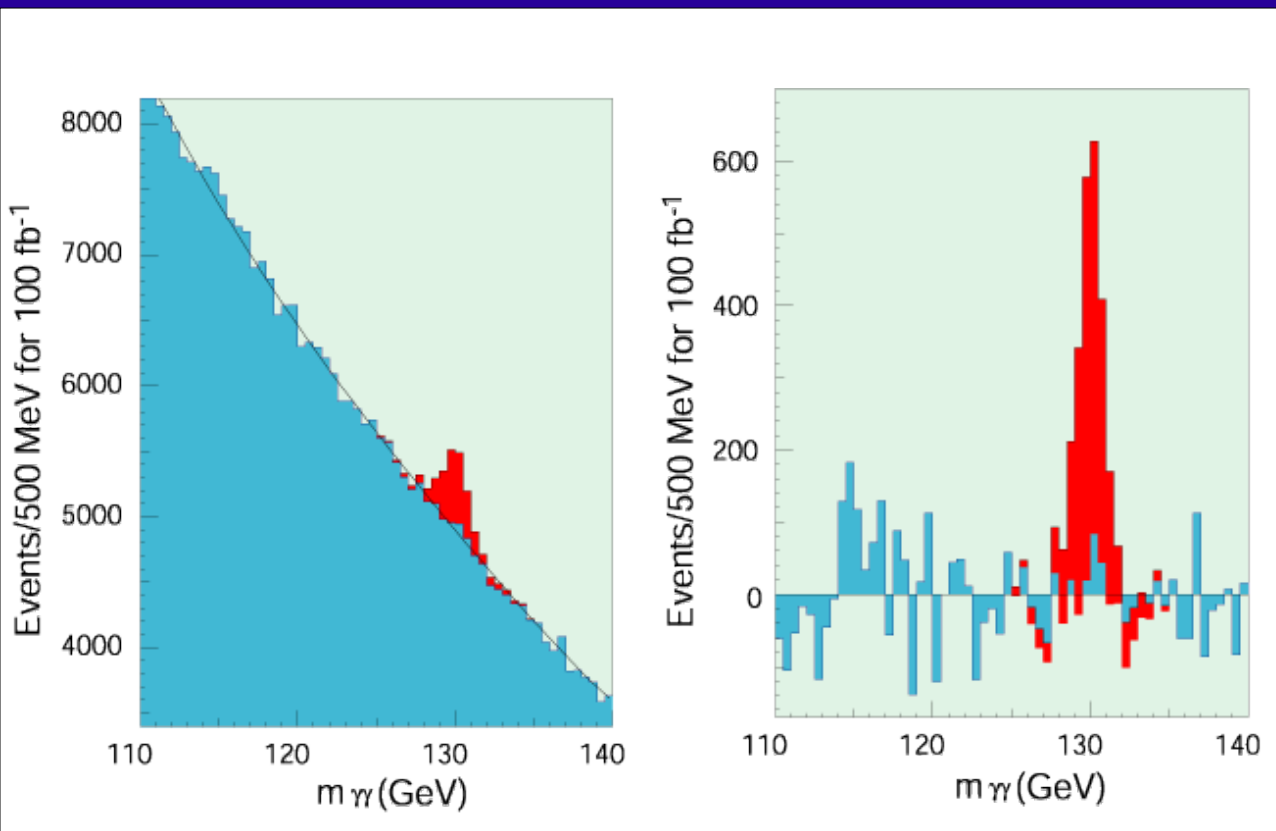

- Continuing the example: if there is a Higgs at low mass, then we'll need photons to find a clear signal for it.
- Plots are the CMS simulation for $H \rightarrow \gamma\gamma$, with backgrounds.
- Analysis can only be performed with well understood photons!

The LHC:

- A factor of seven increase in energy is nothing to sneeze at ($2 \text{ TeV} \rightarrow 14 \text{ TeV}$).
 - This is especially relevant to dibosons, if there is no Higgs, then there must be action here! If there is a Higgs, we should see it!
- New detectors, new environment, but similar problems.
- All of the same challenges have to be met at LHC to get the physics out.
- Onward to discovery!



Thank you!

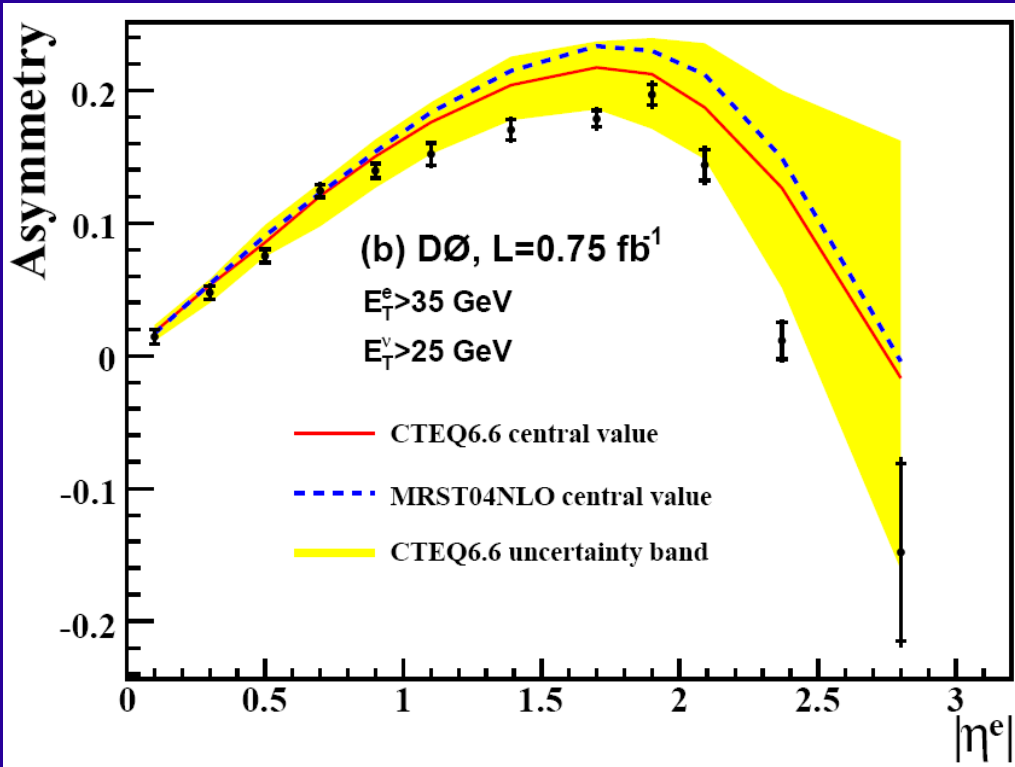

Measurement of the electron charge asymmetry in $pp(\bar{p}) \rightarrow W+X \rightarrow e\nu+X$ events at $\sqrt{s}=1.96$ TeV, 0807.3367 [hep-ex]; PRL 101, 211801 (2008)

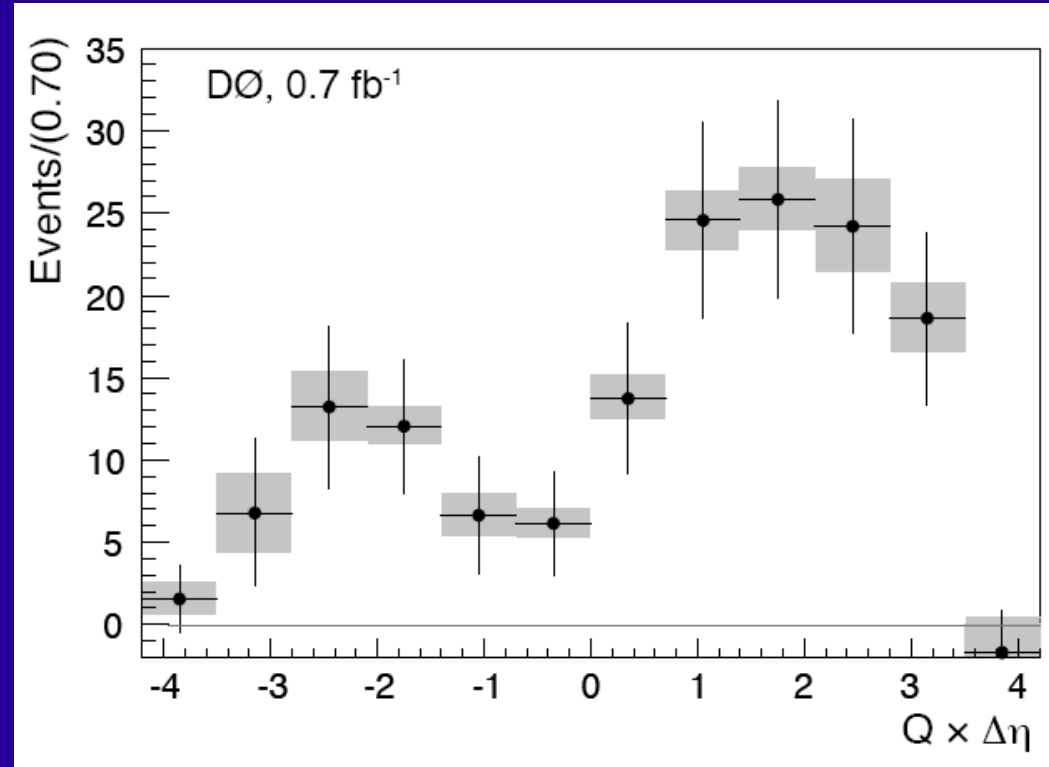

First study of the radiation-amplitude zero in $W\gamma$ production and limits on anomalous $WW\gamma$ couplings at $\sqrt{s}=1.96$ TeV, 0803.0030 [hep-ex]; PRL 100, 241805 (2008)