

Simple acoustical technique for automated measurement of drift tube anode wire tension

Michael Hosack and Thomas Coan *

Physics Department, Southern Methodist University, Dallas, TX 75275, USA

Abstract

We describe a simple and inexpensive acoustical technique that permits rapid, accurate and in-situ measurement of drift tube anode wire tensions even if the anode wire is electrically discontinuous.

1 Introduction

The accurate determination of wire tensions in drift chambers is a necessary quality control step in the construction of properly performing chambers. Numerous techniques are described in the literature[1] that rely on a variety of means to induce oscillations in the wire being measured. Typically, these oscillations induce an emf or change the mutual capacitance between the anode and its neighboring electrodes. These induced effects are then maximized by explicitly tuning the frequency of the input perturbation. The frequency for which the response is maximum is then related to the wire tension by a simple expression for the frequency of possible standing waves on a stretched wire as a function of the wire's tension. Such techniques, while useful, have the drawbacks that the anode wire be electrically continuous and that the input perturbation be explicitly tuned in frequency to maximize the response.

We have developed an automated wire tension measuring scheme that is suitable for drift chambers with electrically discontinuous anode wires and that requires no time-consuming frequency adjustment of the input perturbation. Electrically discontinuous anode wires, formed by fusing a dielectric to two halves of an anode wire, are an expedient occupancy reducing measure for

* Corresponding author. Tel. (+1) 214 768 2497, fax (+1) 214 768 4095, email: coan@mail.physics.smu.edu

chambers exposed to a large flux of charged particles. Our technique was developed to measure the tensions of the electrically discontinuous anodes of the $\simeq 56,000$ channel forward straw tracker of the BTeV project at FNAL. Other detectors, such as the transition radiation tracker of the ATLAS experiment at LHC, also use drift tubes with electrically discontinuous anodes.

2 Principle of the method

The general idea of our technique is to use a short burst of sound with a uniform spectral density over some finite frequency range to excite standing waves on a biased anode wire and to then measure the resulting power spectral density (PSD) associated with the induced current sourced from the anode-cathode capacitive system. The PSD, as shown below, peaks at a frequency that corresponds to the tension of the anode. Exciting the wire with a spectrum of frequencies simultaneously rather than serially with a single frequency allows the tension measurement to be done accurately with great speed.

It is well known that a wire of uniform linear mass density μ under tension T with fixed end-points a distance L apart supports standing waves of frequency

$$f_n = \frac{n}{2L} \sqrt{T/\mu}, \quad (1)$$

where n is a positive integer and labels the $(n - 1)$ th harmonic. As a biased anode vibrates with respect to its neighboring cathode(s), the resulting change in the mutual capacitance between the two produces a current $\dot{Q}(t) = \dot{C}(t)V_0$, where $C(t)$ is the anode-cathode mutual capacitance and V_0 is the constant bias voltage of the anode with respect to the cathode. The current $\dot{Q}(t)$ can be processed by a simple transimpedance amplifier to produce an output voltage $V'(t)$ which in turn can be Fourier analyzed to produce its associated PSD. The frequency at which the PSD peaks is then converted to the anode tension T by Eq. 1.

A sound burst with the desired uniform spectral composition is easily generated using the basic properties of the Fourier transform of a function in the time domain $h(t)$ and its conjugate in the frequency domain $H(f)$:

$$H(f) = \int_{-\infty}^{\infty} h(t) e^{2\pi i f t} dt \quad (2)$$

$$h(t) = \int_{-\infty}^{\infty} H(f) e^{-2\pi i f t} df, \quad (3)$$

where the corresponding “one-sided” PSD of the function $h(t)$ is defined as

$$P_h(f) \equiv |H(f)|^2 + |H(-f)|^2 \quad 0 \leq f < \infty. \quad (4)$$

If we further define a constant $H(f)$, within an overall scaling factor, as

$$H(f) = \begin{cases} \pi & \text{if } a_1/(2\pi) < |f| < a_2/(2\pi) \\ 0 & \text{otherwise,} \end{cases} \quad (5)$$

where a_1 and a_2 are constants, then from Eq. (3) the appropriate voltage waveform $h(t)$, again within an overall scale factor, to feed a sound speaker to produce our sound burst is:

$$h(t) = \sin(a_2 t)/t - \sin(a_1 t)/t \quad (6)$$

$$= a_2 \operatorname{sinc}(a_2 t/\pi) - \operatorname{sinc}(a_1 t/\pi). \quad (7)$$

3 Procedure and test results

We demonstrate our tension measuring technique using a representative prototype straw tube from the BTeV project. The straw tube is comprised of a 20 μm diameter gold-plated tungsten anode wire inside a 4 mm diameter kapton straw with a conductive inner surface. The anode is centered inside the 100 cm long straw using special helical fixtures that set the radial position of the anode at both straw ends as well as at the straw mid-point. The distance between neighboring fixtures, corresponding to node locations for standing waves, is $L = 50$ cm. A simple pulley and hanging mass system allows the anode to be tensioned with different mass values. The anode is biased at $V_0 = 70$ V with respect to the cathode, far less than the typical bias value used for actual tracking operation. The front face of a 1.5 Watt personal computer (PC) speaker used to vibrate the anode is positioned 5 cm above the straw mid-point and the volume level is set at 30

The sound generation and output signal processing are done using a combination of commercial hardware and software (LabVIEW), an op-amp configured as a transimpedance amplifier and the speaker. A standard LabVIEW routine calculates the sinc function of Eq. 7 using values of a_1 and a_2 that make $H(f)$ loosely bracket the frequency of the fundamental mode corresponding to the anode wire’s anticipated tension. For example, in the case of the anode tensioned to 50 gm, $f_1 \simeq 225$ Hz so that a_1 and a_2 can be set to correspond to $f = 200$ Hz and $f = 250$ Hz, respectively.

We generate a speaker voltage proportional to $h(t)$ by first software sampling $h(t)$ (at a rate four times faster than what we eventually sample our final output signal with) and then using a digital-to-analog converter (DAC) located on a National Instruments DAQ card¹ to feed the speaker a sequence of voltage levels. The duration of the voltage waveform is 1 second and its quality can be measured by using an analog-digital-converter (ADC) located on the same DAQ card. Fig. 1 shows the speaker voltage and its apparent sinc-like shape. After digitization, the corresponding one-sided PSD of the speaker voltage is computed using the fast fourier transform (FFT) technique contained in a standard LabVIEW routine. The result is shown in Fig. 2, showing clearly its flat-top nature and the desired bracketing of the anode’s nominal fundamental frequency.

The equivalent circuit of the biased straw tube and its readout circuitry is shown in Fig. 3. The FET-input op-amp is a Burr-Brown OPA137P and the large feedback resistor is required because the straw’s induced current is quite small. (The estimated fractional change in the straw’s capacitance due to anode wire vibration is $\delta C/C \sim 10^{-3}$. See Ref. [2].) The op-amp’s output voltage $V'(t)$ is digitized by the DAQ card’s ADC (we uniformly sample 10,000 times during the 1-second sound burst) and then fourier analyzed using the FFT algorithm. The computation time for the FFT is negligible. The digitized $V'(t)$ is shown in Fig. 4 and its PSD as a function of frequency is shown in Fig. 5. A clear peak at the nominal fundamental frequency of the anode is seen. The total time for sound generation and signal processing is 2-3 seconds per anode.

Many systematic tests were performed to verify the robustness of the technique. Altering the speaker position along the straw length and changing the horizontal orientation of the anode to vertical had no appreciable effect on the peak frequency of the output voltage PSD. The peak frequency was similarly insensitive to a reduction of the anode-cathode bias voltage by a factor of two. Multiple measurements, made by detaching and reattaching the same 50 gm hanging mass for each trial, changed the PSD’s peak frequency by ~ 1.5 Hz. We estimate the total systematic error in the measured fundamental frequency to be ~ 2.5 Hz, dominated by the uncertainty in the precise value of L to use in Eq. 1.

The dynamic range of the technique was investigated by hanging different masses in the range 20-100 gm from the anode, producing a nominal anode fundamental frequency in the range 145-320 Hz. For each nominal tension, the above procedure was repeated and the peak PSD frequency determined. Each resulting PSD plot was similar in shape to Fig. 5. The cumulative results are shown in Fig. 6 where the measured peak PSD frequency f_p (each data point

¹ NI PCI-6036E

is an average of 20 individual measurements) is plotted as a function of the square root of the hanging mass $\sqrt{m_H}$. The heavy line is a linear fit of f_p to $\sqrt{m_H}$, with a $\chi^2/\text{degree-of-freedom} = 1.1$, showing excellent agreement with the form of Eq. 1.

Acknowledgements

We thank D. Rust for useful technical discussions.

References

- [1] E.R. Mueller, Nucl. Instr. and Meth. A 281 (1989) 652; K. Lang, J.Ting and V. Vassilakopoulos, [hep-ex/9810023](#) and references therein.
- [2] M. Anderson et al., ATLAS memo, ATL-INDET-200-018, unpublished.

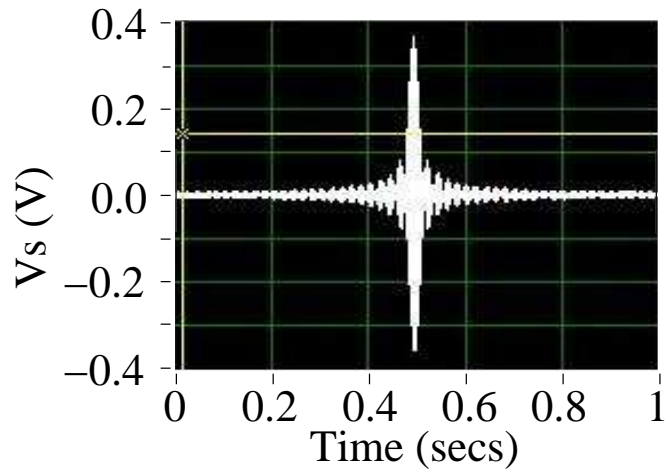

Fig. 1. The speaker voltage V_s as a function of time over its 1-second duration.

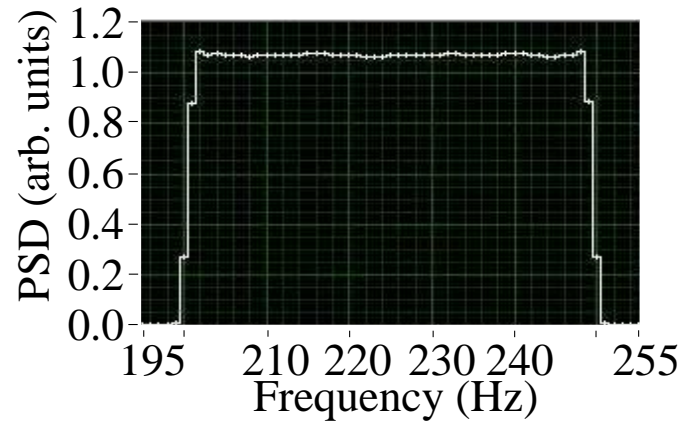

Fig. 2. The one-sided PSD of the speaker voltage. Note the flat top and the sharp edges centered around the nominal fundamental frequency (225 Hz) of the tensioned anode.

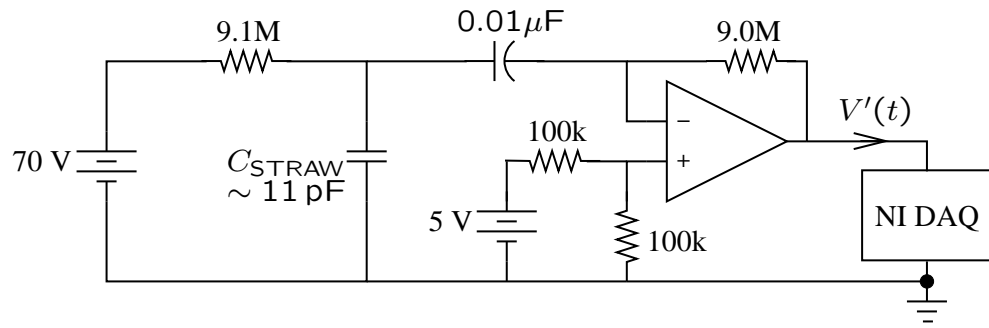

Fig. 3. Block diagram of the straw tube readout circuit. NI DAQ refers to a commercial data acquisition card and a special purpose connector (NI BNC-2110) from National Instruments Corp.

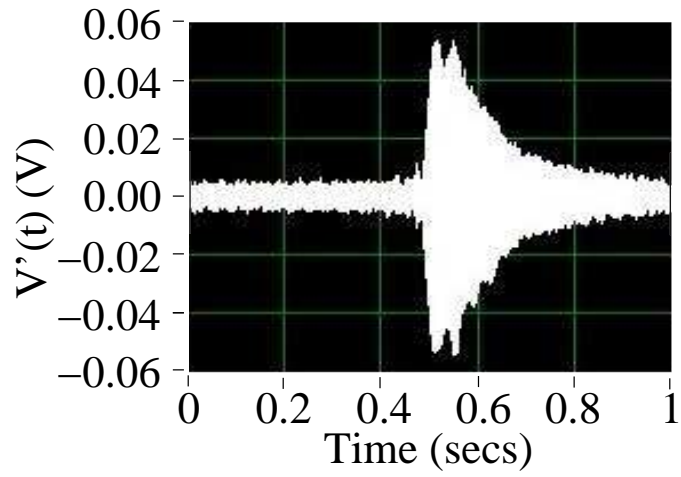

Fig. 4. Envelope of the digitized output signal $V'(t)$ over the 1-second duration of the sound burst.

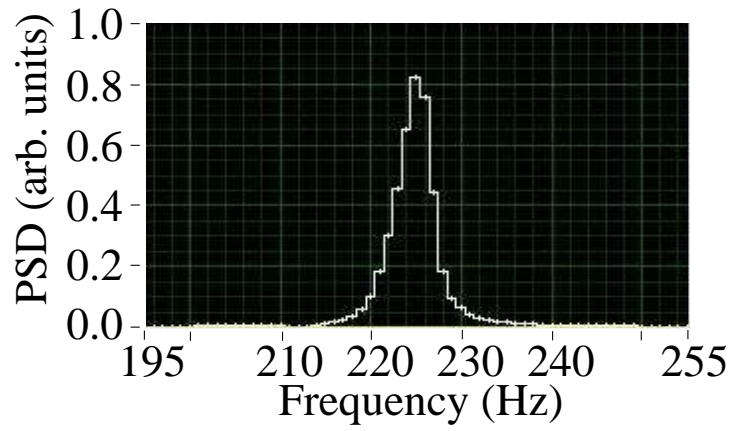

Fig. 5. Typical one-sided PSD of the output voltage $V'(t)$ as a function of frequency. The vertical scale is arbitrary. The peak corresponds to the fundamental frequency of the tensioned anode wire.

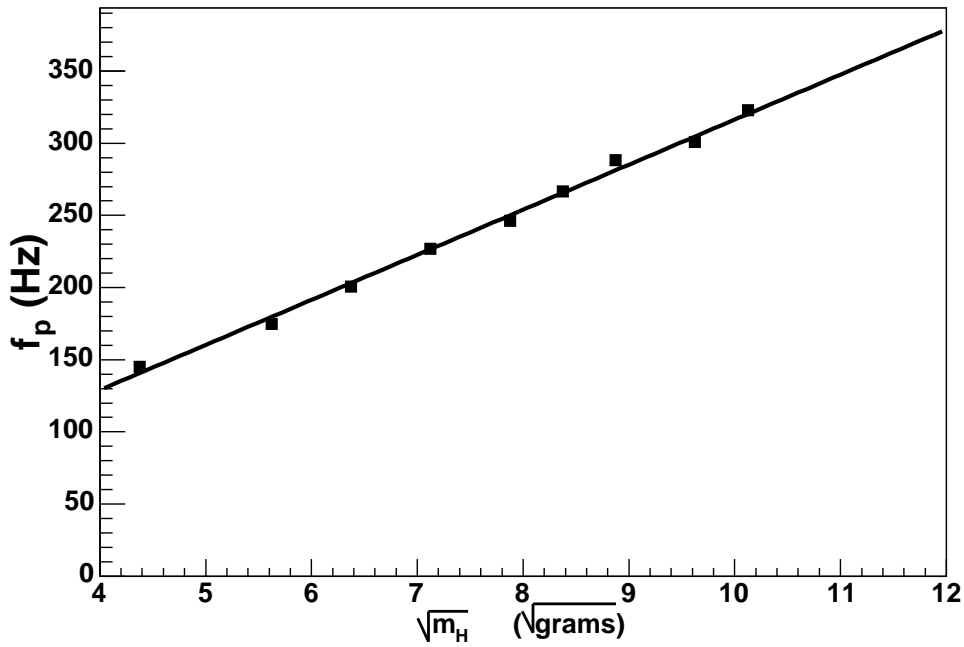

Fig. 6. Peak frequency f_p of the output voltage PSD as a function of the square root of the hanging mass m_H . Each data point is the average of 20 individual measurements. (The error bars are smaller than the data markers.) The heavy line is a linear fit of f_p to $\sqrt{m_H}$.